

INCH-POUND

MIL-HDBK-1013/10

14 MAY 1993

SUPERSEDING

See para 1.2

MILITARY HANDBOOK
DESIGN GUIDELINES FOR SECURITY
FENCING, GATES, BARRIERS, AND GUARD FACILITIES



AMSC N/A

AREA FACR

DISTRIBUTION STATEMENT A. APPROVED FOR PUBLIC RELEASE; DISTRIBUTION IS UNLIMITED.

ABSTRACT

This military handbook, MIL-HDBK-1013/10, provides the latest state-of-the-art criteria for security fencing, gates, barriers, and guard facilities and is primarily intended for use by Naval Facilities Engineering Command (NAVFACENCOM) design engineers and architectural and engineering firms. The contents cover specific criteria to be used during the selection, design, and construction of security fencing, gates, barriers, and guard facilities.

FOREWORD

This military handbook has been developed from an evaluation of security requirements contained in Department of the Navy and DoD directives, surveys of new materials and construction methods, evaluation and selection of the best design practices of Naval Facilities Engineering Command (NAVFAC), other Government agencies, and the private sector. It uses national, professional, and other society, association, and institute standards to the maximum extent feasible. Any deviations from the criteria contained in this handbook for the planning, engineering, and design of physical security fencing, gates, barriers, and/or guard facilities for Navy shore facilities shall not be made without prior approval of NAVFACENGCOC headquarters (Code 04).

Design of security fencing, gates, barriers, and guard facilities does not remain static any more than the functions they serve or the technology they use. As such, recommendations for improvement of this handbook are encouraged from within the Navy, other Government agencies, and the private sector. Recommendations should be furnished on DD Form 1426 (provided inside the back cover) to the Naval Civil Engineering Laboratory (NCEL), Code L30, 560 Laboratory Drive, Port Hueneme, CA 93043-4328, telephone DSN 551-5743, (805) 982-5743.

THIS HANDBOOK SHALL NOT BE USED AS A REFERENCE DOCUMENT FOR PROCUREMENT OF FACILITIES CONSTRUCTION. IT IS TO BE USED IN THE PURCHASE OF FACILITIES ENGINEERING STUDIES AND DESIGN (FINAL PLANS, SPECIFICATIONS, OR ESTIMATES). DO NOT REFERENCE IT IN MILITARY OR FEDERAL SPECIFICATIONS OR OTHER PROCUREMENT DOCUMENTS.

PHYSICAL SECURITY CRITERIA MANUALS

<u>Criteria Manuals</u>	<u>Title</u>	<u>Preparing Activity</u>
MIL-HDBK-1013/1	Design Guidelines for Physical Security of Fixed Land-Based Facilities	NCEL
DM-13.02	Commercial Intrusion Detection Systems (IDS)	LANTDIV
MIL-HDBK-1013/4	Instruction for Design, Fabrication and Construction/Installation of Secure Enclosures	NCEL
MIL-HDBK-1013/5	Steel-Ply Wall Hardening Selection and Installation Guide	NCEL
MIL-HDBK-1013/7	Security Hardware Installation, Operation and Maintenance	NCEL
MIL-HDBK-1013/8	Combination Locks	NCEL
MIL-HDBK-1013/10	Design Guidelines for Security Fencing, Gates, Barriers, and Guard Facilities	NCEL

DESIGN GUIDELINES FOR SECURITY FENCING, GATES,
BARRIERS, AND GUARD FACILITIES

CONTENTS

	<u>Page</u>
Section 1	INTRODUCTION
1.1	Scope 1
1.2	Cancellation 1
1.3	Criteria Documentation 1
1.4	Application 1
1.5	Technical Approach for Fence Design 1
1.6	NATO Criteria 1
1.7	Preliminary Physical Security Considerations 2
1.8	Fencing Modifications 3
1.9	Cost of Security 3
Section 2	FENCES
2.1	Application 4
2.2	Related Criteria 4
2.2.1	Initial Barrier Design 5
2.3	Chain-Link Fences 6
2.3.1	Posts and Bracing 6
2.3.2	Chain-link Fence Fabric 7
2.3.3	Outriggers 7
2.3.4	Accessories 8
2.3.5	Erection Requirements 8
2.3.5.1	Fence Placement 8
2.3.5.2	Posts, Top Rails, and Bracing 9
2.3.5.3	Chain-Link Fence Fabric Mounting 9
2.3.5.4	Outriggers 10
2.3.5.5	Accessories 10
2.3.6	Special Security Features 10
2.3.6.1	Clear Zones 10
2.3.6.2	Patrol Roads 11
2.3.6.3	Signs 12
2.3.6.4	Drainage Culverts and Utility Openings 12
2.3.6.5	Drainage Crossings 14
2.3.6.6	Tunneling 17
2.3.7	Maintenance Considerations 18
2.3.8	Erosion Control 18
2.3.9	Grounding 18
2.4	Special Requirements for Fences Equipped with Intrusion Detection Systems (IDS) Sensors 18
2.4.1	Taut-Wire Fences 18
2.4.2	Special Requirements 19
2.4.3	IDS Funding 19

	<u>Page</u>
Section 2.5	Penetration-Resistant Barriers 19
2.5.1	Reinforcement of Perimeter Chain-Link Fence . . . 20
2.5.2	Additional Barriers 22
Section 3	GATES
3.1	Application 23
3.2	Related Criteria 23
3.3	Types of Gates 23
3.4	Design 28
3.4.1	Selection of Gate Type 28
3.4.1.1	Personnel Gates 28
3.4.1.2	Vehicle Gates 29
3.4.1.2.1	Sliding Gates 29
3.4.1.2.2	Overhead Gates 30
3.4.1.2.3	Swing Gates 30
3.4.1.2.4	Vertical Lift Gates 31
3.4.2	Hinges 31
3.4.3	Locking System 31
3.4.4	Gate Power-Operators 32
3.4.4.1	Gate Power-Operator Design 33
3.4.4.1.1	Sliding Gate Power-Operators 33
3.4.4.1.2	Swing Gate Power-Operators 33
3.4.4.1.3	Gate Power-Operator Peripherals 34
3.5	Number and Location of Gates 35
3.6	Traffic Control 35
3.7	Penetration-Resistant Barriers 37
3.7.1	Reinforcement of Swing Gates 37
3.7.2	Reinforcement of Sliding and Vertical Lift Gates . 41
Section 4	GUARD FACILITIES
4.1	Application 46
4.2	Related Criteria 46
4.3	Sentry Booths and Gatehouses 46
4.3.1	Location 47
4.3.2	Site-Built Structures 47
4.3.2.1	Structure Size 47
4.3.2.2	Windows 48
4.3.2.3	Floors 48
4.3.2.4	Construction 48
4.3.2.5	Environmental Control 49
4.3.2.6	Lighting 49
4.3.2.7	Grounding 49
4.3.2.8	Fortification 49
4.3.3	Prefabricated Structures 49

		<u>Page</u>
Section 4.4	Guard Towers	51
4.4.1	Location and Height	51
4.4.2	Site-Built Structures	52
4.4.2.1	Structure Size	52
4.4.2.2	Windows	52
4.4.2.3	Construction	52
4.4.2.4	Environmental Control	54
4.4.2.5	Lighting	54
4.4.2.6	Grounding	54
4.4.2.7	Fortifications	54
4.4.2.8	Stairs and Ladders	54
4.4.3	Prefabricated Structures	54
4.4.4	Ballistic-Resistant Materials Data	55

APPENDIX

APPENDIX A	Manufacturers	56
------------	-------------------------	----

FIGURES

Figure 1	Fabric and Wire Fastener, Power Driven	9
2	Steel Culvert Grill	13
3	Concrete Culvert Grill	13
4	Removable Grating for Culverts	14
5	Large Culvert with Short Honeycomb Pipes	15
6	Swale Crossing With Ground Stakes	15
7	Swale Crossing Embedded in Concrete	16
8	Bar Grill embedded in Concrete	16
9	Chain-Link Fence Embedded in Concrete Sill	17
10	Steel Cable-Reinforced Chain-Link Fence	21
11	Deadman Anchor	21
12	Single Swing Gate	24
13	Double Swing Gate	24
14	Single Cantilevered Gate	25
15	Double Cantilevered Gate	25
16	Single Wheel-Supported (V-groove) Sliding Gate	26
17	Single Overhead Supported Gate	26
18	Double Overhead Supported (Biparting) Gate	27
19	Turnstile (Rotational) Gate	27
20	Entry Control Point Layout	36
21	Nuclear Weapons Storage Site Entry Control Facility	37
22	Chain and Wire Rope Reinforced Gate	38
23	Wire Rope Interwoven at Gate Post	39
24	Chain and Wire Rope Locking System	39
25	Wire Rope Clamps	40

		<u>Page</u>
Figure 26	Hydraulically Swaged Wire Rope Fitting.	40
27	Cable Reinforcement for a Sliding Gate.	42
28	Cable Reinforcement of a Vertical Lift Gate	42
29	Chain and Wire Rope Reinforcing Sliding Gate. . . .	43
29	Chain and Wire Rope Reinforcing Sliding Gate - Continued	44
30	Chain and Wire Rope Reinforcing a Vertical Lift Gate	45
31	Site-Built Sentry Booth/Gatehouse Floor Plan	48
32	Typical Prefabricated Sentry Booth	50
33	Guard Tower Designed by Sandia National Laboratories	53
34	Basic Components of a Chain-Link Fence	61

TABLES

Table 1	Gate Post Foundations	31
REFERENCES	57
GLOSSARY	61

Section 1: INTRODUCTION

1.1 Scope. This military handbook provides guidance and detailed criteria for the design, selection, and installation of new security fencing, gates, barriers, and guard facilities for perimeter boundaries of Navy and Marine Corps installations or separate activities, and designated restricted areas. Primarily, the criteria herein is based on the following Chief of Naval Operations Instructions (OPNAVINSTs):

a) OPNAVINST 5530.13A, Department of the Navy Physical Security Instruction for Conventional Arms, Ammunition, and Explosives (AA&E).

b) OPNAVINST 5530.14B, Department of the Navy Physical Security and Loss Prevention.

c) OPNAVINST C8126.1, Navy Nuclear Weapon Security Manual.

1.2 Cancellation. This military handbook, MIL-HDBK-1013/10, supersedes the following portions of NAVFAC Design Manual (DM) 5.12, Fencing, Gates and Guard Towers, dated October 1979: Section 1, paragraph 3; Section 2, paragraphs 2c and 3a; Section 3, paragraphs 1(1) and 1(d); portions of Table 1, dealing with Applications-Security, Perimeter, Nuclear Weapons; and, Table 2 in its entirety.

1.3 Criteria Documentation. Where criteria documentation such as Federal Specifications, Military Specifications, Naval Facilities Engineering Command (NAVFACENCOM) Guide Specifications, etc., are cited, the latest version should be used for design.

1.4 Application. Physical barriers will be established around all perimeter boundaries and designated restricted areas as defined in Chapter 3 of OPNAVINST 5530.14B, Chapter 5 of OPNAVINST 5530.13A, and Chapter 3 of OPNAVINST C8126.1.

1.5 Technical Approach for Fence Design. This handbook was developed to lead the designer through the detailed criteria required to establish a physical barrier around any Navy and Marine Corps perimeter boundary and designated restricted area. Perimeter boundaries and restricted area fence and barrier criteria from OPNAVINST 5530.14B have been used in this handbook as a baseline to design security fences. Where different or special requirements for AA&E or nuclear restricted areas are specified in OPNAVINST 5530.13A or OPNAVINST C8126.1, they are contained herein under the appropriate subject title and section.

1.6 NATO Criteria. There are differences between the criteria contained in this handbook and the criteria authorized or directed by the North Atlantic Treaty Organization (NATO). While this handbook may be used as a baseline for design of security fencing, gates, barriers, and guard

facilities in Europe, obtain and follow specific NATO criteria to assure that specified NATO security requirements are met when designing these security components.

1.7 Preliminary Physical Security Considerations. Security fences will not stop a determined intruder. To be effective, such barriers must be augmented by security force personnel and other means of protection, detection, delay, and assessment. Security fences are used primarily to:

- a) define the perimeter of a restricted area.
- b) provide a physical and psychological deterrent to entry while serving notice that entry is not freely permitted.
- c) prevent accidental entry.
- d) optimize security force operations.
- e) enhance detection and apprehension of intruders.
- f) channel and control the flow of personnel and vehicles through designated portals.

Keep these factors in mind while proceeding with the security fence design.

Prior to making decisions to employ security fencing, perform a thorough risk and threat analysis to determine the degree of physical security required. As indicated in Chapter 2 of Chief of Naval Operations Instruction (OPNAVINST) 5530.14B, extensive and costly security measures may be justified in certain cases to protect certain assets of security interest; however, ultimately the commanding officer of an activity is responsible for complying with established security requirements while at the same time working to achieve economy. To achieve this objective, higher echelon security requirements must be clearly understood. Additionally, evaluate the relative criticality and vulnerability of the security interest in relation to a ranking of potential threats, and calculate the specific level of security to ensure the best possible protection for that threat level in a cost-effective manner. Only after the above preliminary factors are addressed can a proper design be initiated. See MIL-HDBK-1013/1, Design Guidelines for Physical Security of Fixed Land-Based Facilities, for guidance and more detailed procedures which may be helpful in the decision process.

It is imperative that security fencing requirements for restricted areas be evaluated on a case-by-case basis. Installing large quantities of security fencing around an entire outer perimeter may not be practical or cost-effective, and may not improve security, particularly in remote and unpopulated areas. Consider the following:

a) If the outer perimeter of the installation has adequate security fencing, then fencing of inner zones may not be required.

b) If the outer perimeter of the installation has barbed wire or hog-wire fencing or no fencing, security fences for inner facilities or storage areas may be more practical and cost-effective.

c) If the outer perimeter of the installation is partially fenced with a security fence, it may be more cost-effective to provide security fencing for the remainder of the outer perimeter rather than install security fencing around inner restricted areas.

d) If natural barriers such as mountains, cliffs, rivers, seas, or other difficult-to-traverse terrain form portions of the perimeter, then security fencing of the inner restricted areas may be more practical and cost-effective than providing security fencing either along or through these difficult-to-traverse areas.

In some cases, a request for a permanent exception to fencing requirements submitted in accordance with OPNAVINST 5530.14B may be more appropriate than erecting costly security fencing.

1.8 Fencing Modifications. Existing serviceable 6-foot (1.8-meter (m)) chain link fences (without outriggers) and gates constructed under the old version of OPNAVINST 5530.13A requirements do not need to be modified or replaced to meet the new OPNAVINST 5530.13A, 7-foot (2.1-m) (without outrigger) requirement.

Increasing the height of chain-link fencing by 1 or 2 feet (0.30 or 0.61 m) may, at best, increase the time to penetrate by going over the fence by only a couple of seconds. However, it has no effect on the time to penetrate the fence by cutting.

1.9 Cost of Security. Generally, physical security cost expenditures should be based upon the cost of the item to be protected, possible damage that the loss of the item could inflict upon the civilian population, and the importance of the item to the overall security and readiness posture of the command. The cost of security is frequently greater than the dollar value of the property or material protected. Sensitive items that may be a threat to the civilian population or vital to national security will be provided additional protection commensurate with their sensitivity and the threat to their loss or destruction.

Section 2: FENCES

2.1 Application. Requirements for security fencing generally fall into three categories:

- a) General security and loss prevention.
- b) Category I and II conventional arms, ammunition, and explosives (AA&E). (Security fencing will not be provided for Category III and IV AA&E storage facilities unless it is determined necessary based on an assessment of local threats, vulnerabilities, and cost-effectiveness.)
- c) Nuclear weapons.

General design requirements for these security categories are contained in associated OPNAVINSTs. OPNAVINST 5530.14B provides requirements for general physical security and loss prevention, OPNAVINST 5530.13A provides special requirements for the protection of conventional AA&E, and OPNAVINST C8126.1 and NAVFACINST 11012.134A cover special requirements for nuclear weapons.

2.2 Related Criteria. The perimeter boundaries of all Navy and Marine Corps installations or separate activities will be either fenced or walled, and posted to establish a legal boundary. This defines the perimeter, provides a buffer zone, facilitates control, and makes accidental intrusion unlikely. It is important that consultation be made with local authorities to ensure that posting of barriers in areas of concurrent or proprietary jurisdiction complies with local or state trespass laws.

Establish a protective perimeter around all designated restricted areas. The protective perimeter will be a chain-link fence, taut-wire fence, the exterior walls of a structure, or a combination thereof. OPNAVINSTs state that when walls are used as a barrier, they will provide penetration resistance equivalent to, or greater than, the fence. In general, even security fences provide only seconds of penetration resistance. Stud and girt walls are the least penetration resistant of normal wall construction and will provide at least 1 minute of penetration resistance against a low threat level attack using limited hand tools. Therefore, most structure walls will provide equivalent or greater penetration resistance to fences.

Determine the type of barrier to be used after a study of local conditions and applicable directives. The barrier or combination of barriers used must afford equal and continuous protection along the entire perimeter of the restricted area. When a section of natural or structural barriers (or lack thereof) provide a lesser degree of protection, other supplementary means to detect and assess intrusion attempts must be provided or a waiver or exception requested.

Mesh openings will not be covered, blocked, or laced with material which would prevent a clear view of personnel, vehicles, or material in outer perimeter zones or areas. In those instances where the commanding officer determines obscuration to be more advantageous for protecting assets within the fenced area, a request for waiver or exception must be submitted. See OPNAVINST 5530.14B.

2.2.1 Initial Barrier Design. When developing the design of security fencing, gates, barriers, and guard facilities, begin with the general design requirements contained in the appropriate OPNAVINST for the type of restricted area involved. Make an on-site inspection of the facility and area involved in the design. During the on-site inspection and during subsequent review, consider:

- a) What types of walls or fences are present, their condition, and their adequacy to meet the design requirements specified in this handbook.
- b) Proximity of protected area to public property.
- c) Location and isolation of storage facilities.
- d) Sensitivity of protected materials, mission, and personnel.
- e) How the newly designed security barrier will best integrate with the existing surroundings.
- f) Operational requirements.
- g) The desirability or requirement for Intrusion Detection System (IDS) sensors along the perimeter, or the need for Close Circuit Television (CCTV).
- h) The extent of local criminal activity and the protected area's vulnerability to that activity.
- i) What, if any, local building codes or ordinances regulate construction or upgrades of the perimeter barrier system contemplated.
- j) Any legal requirement to define the boundary of the protected area.
- k) The need to make an engineering analysis to determine the stability of the soil.
- l) Environmental conditions.
- m) Safety and fire protection regulations.

2.3 Chain-Link Fences. Chain-link fencing is the type of structural barrier most commonly used to enclose restricted areas where fencing is required. Fabricate new and replacement fencing enclosing designated restricted areas, exterior to structures, with chain-link components. While chain-link fences are expensive, they require very little maintenance and provide little concealment for intruders. In evaluating the requirements for a perimeter fence, the security planner should remember that many perimeter barriers provide less than 10 seconds of delay time. The construction of a chain-link fence will not only define the protected area and cause an intruder to make an overt action that will demonstrate his intent, but will also provide a structure for installing IDS fence sensors to detect intruders. Another advantage of fence systems is that they provide some explosives and ballistics standoff protection for making the perpetrator breach the fence line to reduce the distance to his target.

Federal Specification RR-F-191 is the primary criteria document for security fence components; however, do not specify aluminum fabric, poles, or accessories for security fence components. Definitions for fence components are provided in American Society for Testing Materials (ASTM) F 552, Definitions of Terms Relating to Chain-Link Fencing, and in the glossary of this handbook.

Take particular attention in areas with harsh environments to determine if Type IV chain-link fabric (which provides a plastic coating over zinc-coated steel) material is desirable. ASTM A 90, Standard Test Method for Weight of Coating on Zinc-Coated Galvanized Iron or Steel Articles, or ASTM A 428, Standard Test Method for Weight of Coating on Aluminum-Coated Iron or Steel Articles may be used to assure adequate protection for chain-link fence components. Use ASTM standards where supplemental criteria is either required or desired.

2.3.1 Posts and Bracing. Ensure all posts for security fencing meet the requirements of Federal Specification RR-F-191/3 for one of the following classes:

- a) Class 1 - Steel pipe.
- b) Class 3 - Formed steel sections.
- c) Class 4 - Steel H-sections.
- d) Class 6 - Steel square sections.

Accomplish bracing with steel truss rods not less than 5/16-inch (7.9-millimeters (mm)) nominal diameter and a turnbuckle for tensioning, conforming to RR-F-191/4.

Use the following ASTM Standards to supplement RR-F-191/3 and RR-F-191/4:

- a) ASTM A 120, Specification for Pipe, Steel, Black and Hot-Dipped Zinc-Coated (Galvanized) Welded and Seamless, for Ordinary Uses.
- b) ASTM F 626, Standard Specification for Fence Fittings (particularly evaluation of corrosion resistance and material compatibility).
- c) ASTM F 669, Specification for Strength Requirements of Metal Posts and Rails for Industrial Chain-Link Fence.
- d) ASTM F 1083, Specification for Pipe, Steel, Hot-Dipped Zinc-Coated (Galvanized) Welded, for Fence Structures.

2.3.2 Chain-Link Fence Fabric. Ensure chain-link fence fabric meets the requirements of RR-F-191/1 for one of the following:

- a) Type I - Zinc-coated steel.
- b) Type II - Aluminum-coated steel.
- c) Type IV - Polyvinyl Chloride (PVC) coated over zinc- or aluminum-coated steel.

Security fences will be fabricated with 9-gauge (3.9-mm) steel wire mesh material (before any coating) with mesh openings not larger than 2 inches (50.8 mm) per side. Ensure the fabric height is 7 feet (2.1 m) and has twisted and barbed selvage at the top and bottom.

The designer may use the following ASTM Standards to supplement RR-F-191/1 for chain-link fabric:

- a) ASTM A 116, Specification for Zinc-Coated (Galvanized) Steel Woven Wire Fence Fabric.
- b) ASTM A 392, Specification for Zinc-Coated Steel Chain-Link Fence Fabric.
- c) ASTM A 491, Specification for Aluminum-Coated Steel Chain-Link Fence Fabric.
- d) ASTM A 817, Standard Specification for Metallic-Coated Steel Wire for Chain-Link Fence Fabric.
- f) ASTM F 668, Standard Specification for Poly Vinyl Chloride (PVC)-Coated Steel Chain-Link Fence Fabric.

2.3.3 Outriggers. Single arm steel barbed wire support arms (outriggers) are required for all station perimeter fences. When specified by the local command, they also may be added to interior restricted area security fences for additional deterrence. Double arm steel barbed wire support arms

are required for nuclear storage areas. Ensure outriggers and barbed wire conform to the requirements of RR-F-191/4. Use ASTM A 121, Standard Specification for Zinc-Coated (Galvanized) Steel Barbed Wire, or ASTM A 585, Standard Specification for Aluminum-Coated Steel Barbed Wire, to supplement RR-F-191/4.

2.3.4 Accessories. Ensure accessories such as steel fittings and components used in the erection of chain-link fences meet the requirements of RR-F-191/4. Use ASTM F 626 to supplement RR-F-191/4. Provide fittings electrolytically compatible with connecting fittings, components, and the fence fabric to inhibit corrosion.

2.3.5 Erection Requirements. The design of security fencing, using the above specified components, will include the following provisions. ASTM F 567, Standard Practice for Installation of Chain-Link Fence, may be used as installation guidance to supplement RR-F-191/GEN.

2.3.5.1 Fence Placement. Security fencing for restricted areas will consist of a single-line fence surrounding the restricted area. When specified by the local commander, two single-line fences may be used to provide additional deterrence. The two fences should be separated by a minimum of 30 feet (9.1 m) and a maximum of not more than 150 feet (45.7 m).

Buildings, structures, waterfronts, and other barriers can be used as a part of a security fence line as long as they provide equivalent protection to the fencing enclosing the restricted area. Since security fencing provides less than 10 seconds of penetration resistance, normal stud and girt walls will provide at least 1 minute of penetration resistance against a low threat level attack using limited hand tools. The designer should be primarily concerned with the windows and doorways in any wall or structure that is, or will become, a portion of the security barrier. Windows and doors that are a part of the security barrier must provide penetration resistance equal to the fence (as a minimum). MIL-HDBK 1013/1 should be consulted to determine the criteria required for windows and doors to provide penetration resistance against a low threat level.

Where portions of structures are a part of the security barrier, they must be capable of being easily observed by security personnel, i.e., guard facilities, CCTV, etc. Structures and land topography (including utility poles, trees, vines, steam pipes, etc.) will not be located so they assist passage over, around, or under a fence.

Security fencing for nuclear weapons restricted areas will consist of two single-line physical boundary fences separated by not less than 30 feet (9.1 m) or not more than 150 feet (45.7 m). Do not use walls of structures housing nuclear weapons or alert nuclear weapons systems as a part of a security fence line.

2.3.5.2 Posts, Top Rails, and Bracing. Top rails will not be specified or allowed for fabrication of security fences. Required bracing for posts will be accomplished with diagonal truss rods and tubular horizontal or diagonal bracing.

All posts and structural supports will be located on the inner side of the fencing. Posts will be installed in concrete in accordance with ASTM F 567. Posts must be vertical within plus or minus 2 degrees in two planes. Each gate, terminal, and end post will be braced with truss rods. Truss rods will be installed diagonally, from near ground level of a gate, terminal, or end post to the top of the adjacent line post, no higher than 6 inches (152.4 mm) down from the top of the fabric. There will be no more than a 50-degree angle between the truss rod and the ground.

2.3.5.3 Chain-Link Fence Fabric Mounting. Fence fabric will be mounted on steel posts. Tension wires will either be interwoven or clipped along the top and bottom row of fabric diamonds. The wire fabric will be secured to posts and tension wires as specified in RR-F-191/4. When a more secure manner of attaching the fabric to posts is desired, a power driven fabric and wire fastener, depicted in Figure 1, may be used (see Appendix A). If the ties or fasteners are coated or plated, the coating or plating must be electrolytically compatible with the fence fabric to inhibit corrosion. Where security fencing adjoins structures, the height of the fencing should be 12 feet (3.7 m) high from the connection point with a building to a point 12 feet (3.7 m) away from the structure if required.

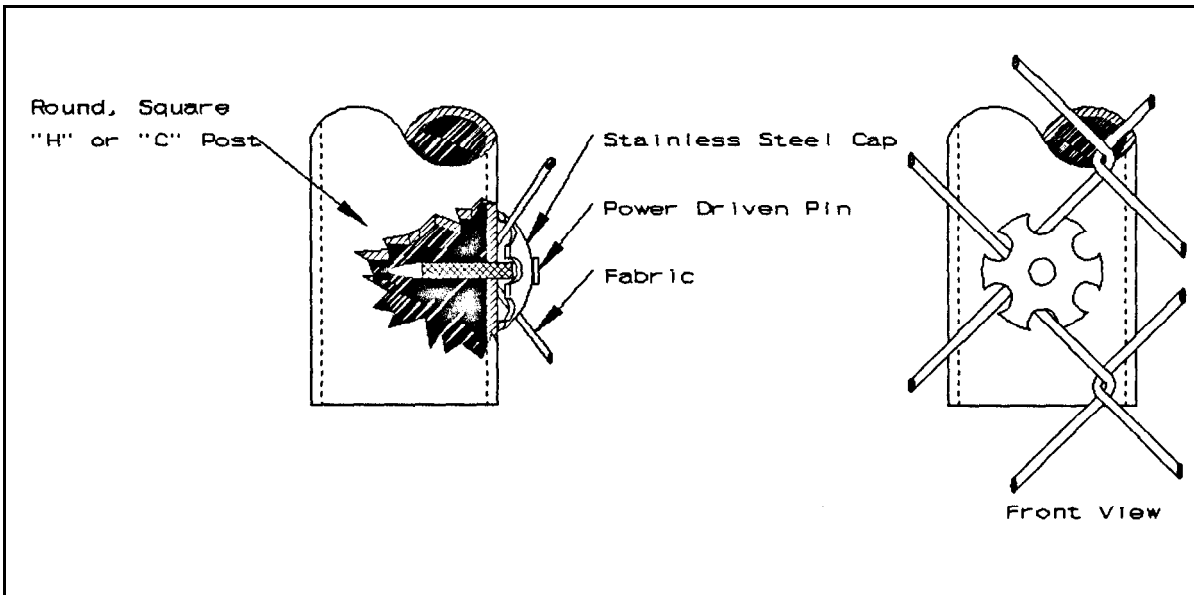

Figure 1.
Fabric and Wire Fastener, Power Driven.

The bottom of the fabric will extend to within 2 inches (50.8 mm) of firm soil. Where stabilization of the soil cannot be accomplished, a soil engineer should be consulted and involved in developing the fence specification. In unstable or shifting soil such as sand, the fabric should either be buried to compensate for the shifting soil or a minimum of 2 inches (50.8 mm) of the bottom selvage of the fence anchored in concrete curbs, sills, hooked steel bars, or similar types of anchoring devices extending below ground level as recommended by the soil engineer. (Frost levels should also be considered when placing curbs, sills, etc.) Even in unstable and shifting soil, the height of fabric and posts must be designed to assure that the top of the fence fabric will be maintained at 7 feet (2.1 m) above existing or anticipated ground level. This often may require that the fabric be 8 feet (2.4 m) or greater, so that sufficient material is buried below the surface or embedded in concrete sills.

At nuclear weapons storage facilities, the bottom 2 inches (50.8 mm) of the fabric will be encased in a 6-inch (152.4-mm) wide concrete sill extending approximately 12 inches (304.8 mm) into the soil around the entire perimeter. In areas where freezing is experienced, the curb must extend below the local frost level for the facility.

2.3.5.4 Outriggers. Steel outriggers will be installed to conform with RR-F-191/4 with their overhang facing outward (away from the protected site), except where the fence must be mounted directly on the property line (instead of at least 18 inches (457.2 mm) back), in which case outriggers can be modified (with exception approval) to be vertical or angle into the site. As a minimum, the outriggers will provide an additional 12 inches (304.8 mm) to the fence height. The top guard fencing adjoining gates may range from a vertical height of 18 inches (457.2 mm) to the normal 45-degree outward protection, but only for sufficient distance along the fence line to open the gates adequately. Outriggers will be permanently affixed to the fence posts with screws or by spot welding.

Nuclear weapons storage facilities will have two steel outriggers installed at opposing 45-degree angles along the top of the fence to form a "V" or a "Y" configuration.

2.3.5.5 Accessories. Secure all fastening and hinge hardware in place by peening or welding. This allows proper operation of components, while preventing disassembly of fencing components or removal of gates.

2.3.6 Special Security Features.

2.3.6.1 Clear Zones. Maintain unobstructed areas or clear zones on both sides of, and between, physical barriers surrounding restricted and non-restricted areas. These areas must be cleared of all vegetation and man-made or natural obstructions that exceed 8 inches (203.2 mm) in height. All clear zones will be clear of visual obstructions such as vines, shrubs, tree limbs, electrical and telephone poles or junction boxes, steam pipes, fire hydrants,

etc., which could provide concealment for an intruder. In addition to security, interior and exterior clear zones provide a 50-foot (15.2-m) wide fire break along the security fence line.

As a minimum, a 30-foot (9-m) interior clear zone will be established inside of the fence line. When possible, a larger interior clear zone should be provided to preclude or minimize damage from thrown objects such as incendiaries or bombs.

An exterior clear zone of at least 20 feet (6.1 m) or greater will be established outside of the fence line. To accomplish this, the fence must be placed a minimum of 20 feet (6.1 m) inside the facility property line. As an exception for perimeter barriers along station property lines, OPNAVINST 5530.14B allows utility poles, signboards, and trees limbs to be in a perimeter clear area as long as these elements are greater than 14 feet (4.3 m) from the perimeter barrier and provided these elements do not obstruct the visibility of the guards. The designer may be required to stagger the perimeter barrier so that the minimum distance between these elements and the security fence is 14 feet (4.3 m) or more. Otherwise these elements must be removed.

At some activities it may not be feasible, practical, or even possible to provide the required minimal clear zones due to various reasons such as lack of Government controlled property, previous construction encroaching the required clear area, etc. In these cases, OPNAVINST 5530.14B requires that compensatory measures and procedures be employed. Construction of any security or perimeter fence that does not provide the minimum clear zones cited above must receive prior approval by an exception as set forth in OPNAVINST 5530.14B. As an alternative when the exterior 20-foot (6.1-m) clear zone cannot be established on Government controlled property, local property owners should be approached to obtain permission to clear and maintain the clear zone outside of the fence.

At nuclear sites, clear areas will extend 30 feet (9.1 m) outside the outer fence line, the entire area between the fences, and 30 feet (9.1 m) inside the inner fence line. These clear areas will be free of all obstacles, topographical features, and visual obstructions including trees, electrical and telephone poles or junction boxes, steam pipes, fire hydrants, etc., exceeding 8 inches (203.2 mm) high.

2.3.6.2 Patrol Roads. When the patrolled perimeter barrier encloses an area generally greater than 1 square mile (2.6 square kilometers (km)), an interior perimeter road in all areas not affected by impassable terrain features must be provided for use by security patrols. Patrol roads that pass through clear areas must be designed to preclude concealment for intruders. Drainage culverts passing under the road in clear zones must be secured at all openings as described herein for drainage and culverts under fences. Drainage ditches along the side of patrol roads shall be designed utilizing shallow or

low angle side slopes which shall not obscure observation from a 4-foot (1.2-m) high line of sight above grade of roadway.

2.3.6.3 Signs. Perimeter security fences for restricted areas will be posted with signs. See OPNAVINST 5530.14B. Signs will be posted on security fences at no less than 200-foot (60.9-m) intervals along the entire perimeter. If the perimeter is the exterior wall of a building or structure, it will be posted at the point of ingress. Where a language other than English is prevalent, warning signs will be posted in both languages.

For nuclear sites, signs will be provided as prescribed in paragraph 3-701, Warning Signs, of OPNAVINST C8126.1. When military working dogs will be used with security forces, appropriate warning signs will be provided as prescribed in Appendix A of OPNAVINST C8126.1.

2.3.6.4 Drainage Culverts and Utility Openings. Special protective measures must be designed for culverts, storm drains, sewers, air intakes, exhaust tunnels, and utility openings, that:

- a) Pass through cleared areas.
- b) Traverse under or through security fences.
- c) Have a cross-section area of 96 square inches (61,939 square mm) or greater, with the smallest dimension being more than 6 inches (152.4 mm).

Such openings and barrier penetrations will be protected by securely fastened grills, locked manhole covers, or other equivalent means that prevent entry or provide security penetration resistance of approximately 10 seconds. When grills are fabricated for this purpose, they may be made by cross-hatching 3/8-inch (9.5-mm) steel bars 9 inches (228.6 mm) on center. The bars will be welded at their intersections. Grills used for culverts will always be placed outside the secure area. For steel pipe, the grill ends will be welded to the pipe as shown in Figure 2. For concrete pipe, the grill ends will be welded to a steel rim that fits snugly over the concrete pipe. The rim and grillwork will be fastened over the concrete pipe and bolted or pinned to the rim of the concrete pipe as shown in Figure 3. As an alternative, the grill ends can be embedded in a concrete headwall that encapsulates the concrete pipe. Care must be taken during design to assure that bars and grills across culverts, sewers, storm drains, etc., are not susceptible to clogging. This must be considered early during the security fence planning phase. Culverts, storm drains, and sewers must be designed with a debris catcher to permit either rapid clearing or removal of grating for cleaning when required. If the inlet is outside the fence line, the debris catcher and grating will be incorporated into the same structure. If the outlet is outside the fence line, the debris catcher will be on the inlet side inside the fence line and the grating on the outlet side. A solution is shown in

Figure 4 (note that the removable grate is locked in place as an added security measure).

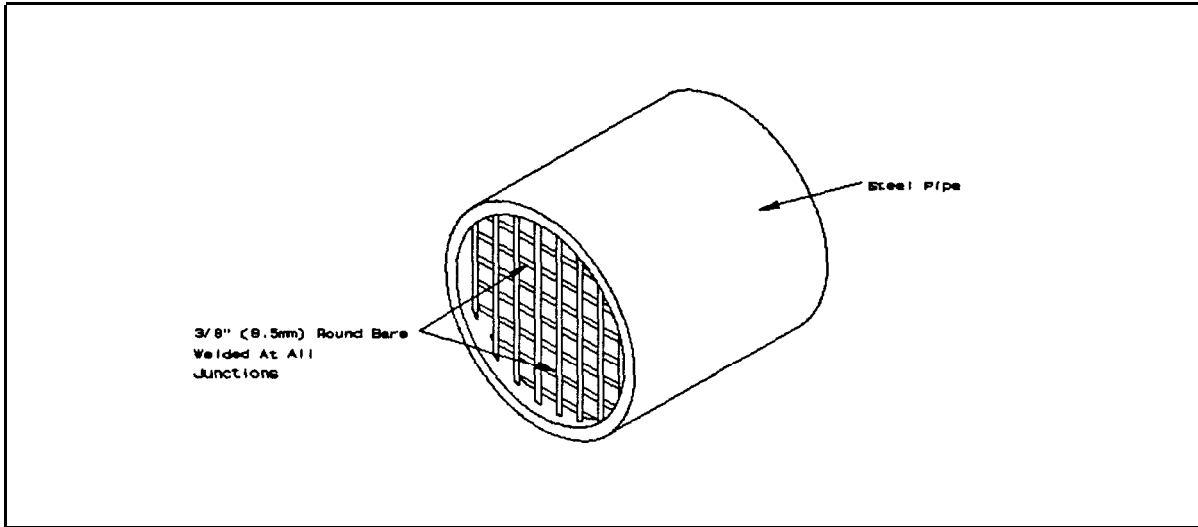

Figure 2.
Steel Culvert Grill.

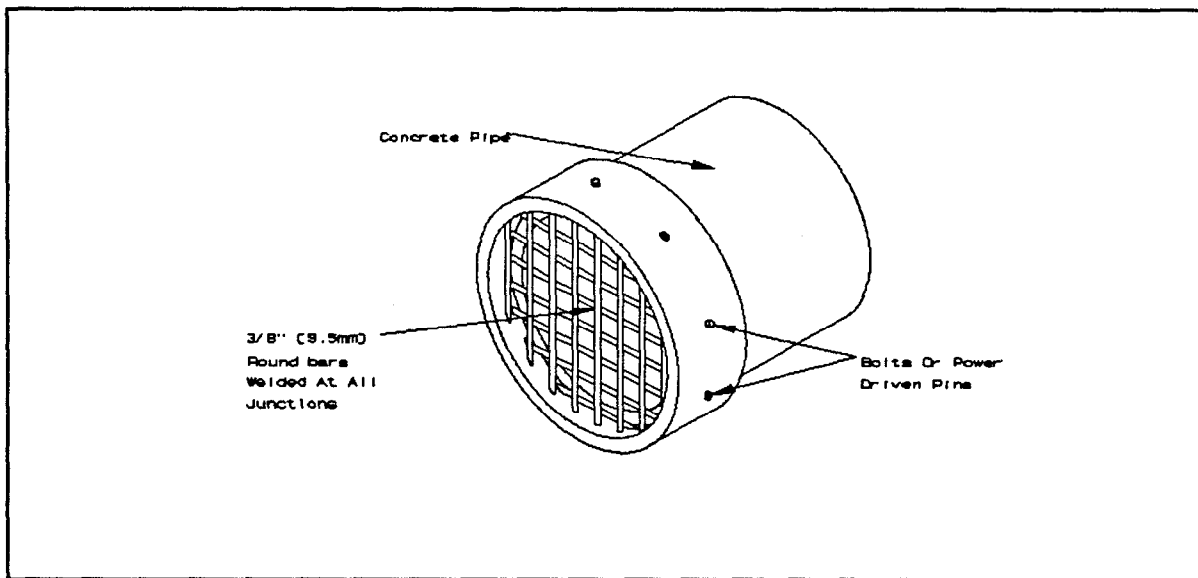

Figure 3.
Concrete Culvert Grill.

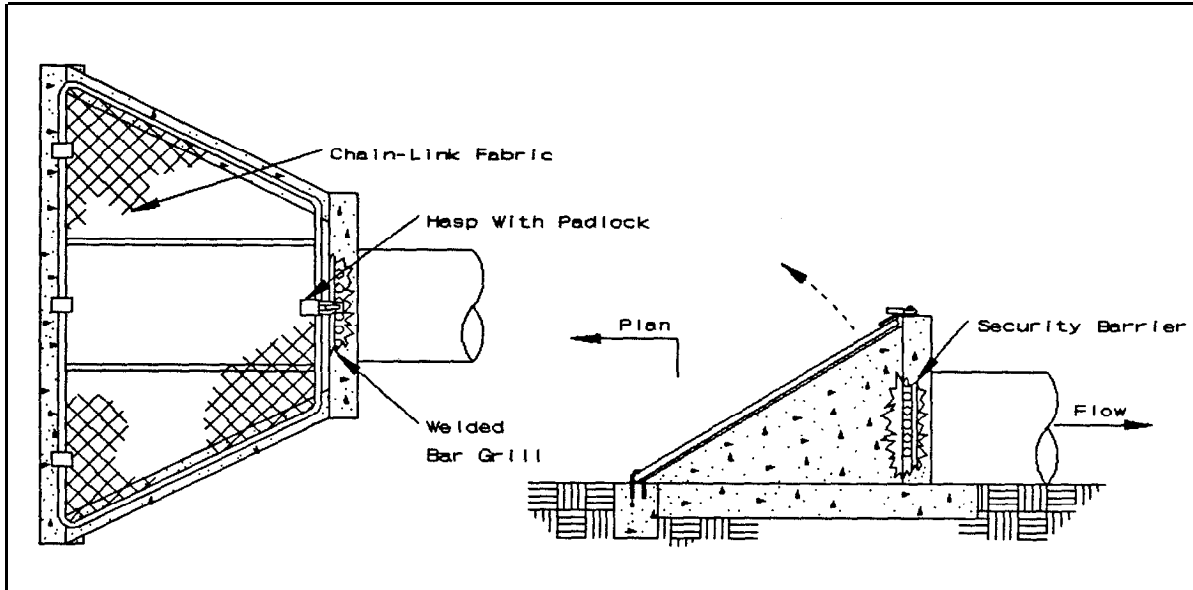

Figure 4.
Removable Grating for Culverts.

As an alternative, drainage structures may be constructed of multiple pipes, each pipe having a diameter of 10 inches (254 mm) or less, joined to each other and to the drainage crossing. An economical solution to secure metal drainage structures is to weld short (approximately 6-inch (152.4-mm) long) multiple pipes, with diameters less than 10 inches (254 mm), in the "in-flow" end of the drainage culvert as shown in Figure 5.

2.3.6.5 Drainage Crossings. Where security fences must cross drainage ditches or swales, the designer must assure that the intruders are prevented from passing under the fence. Where water flow is minor and generally not a problem, the main fence may be carried across a ditch or swale with additional fence added below. The fence added below must be attached every 2 inches (50.8 mm) along the intersection of the two fence sections and either attached to a series of ground stakes secured to the sides and bottom of the ditch, or embedded in a concrete sill in the ditch or swale (see Figures 6 and 7).

Where heavier flows of water are anticipated, a cross-hatched screen type arrangement must be provided below the fence using vertical and horizontal bars similar to those described in the above paragraph. The flow capacity must first be analyzed to determine the size grillwork that will accommodate the maximum amount of water that may be experienced. Rainy seasons and possible debris that can be carried by the flow must be taken into consideration. In any case, not more than 9 inches (228.6 mm) will be allowed between either vertical or horizontal bars, and bars will be welded at each intersection (Figure 8).

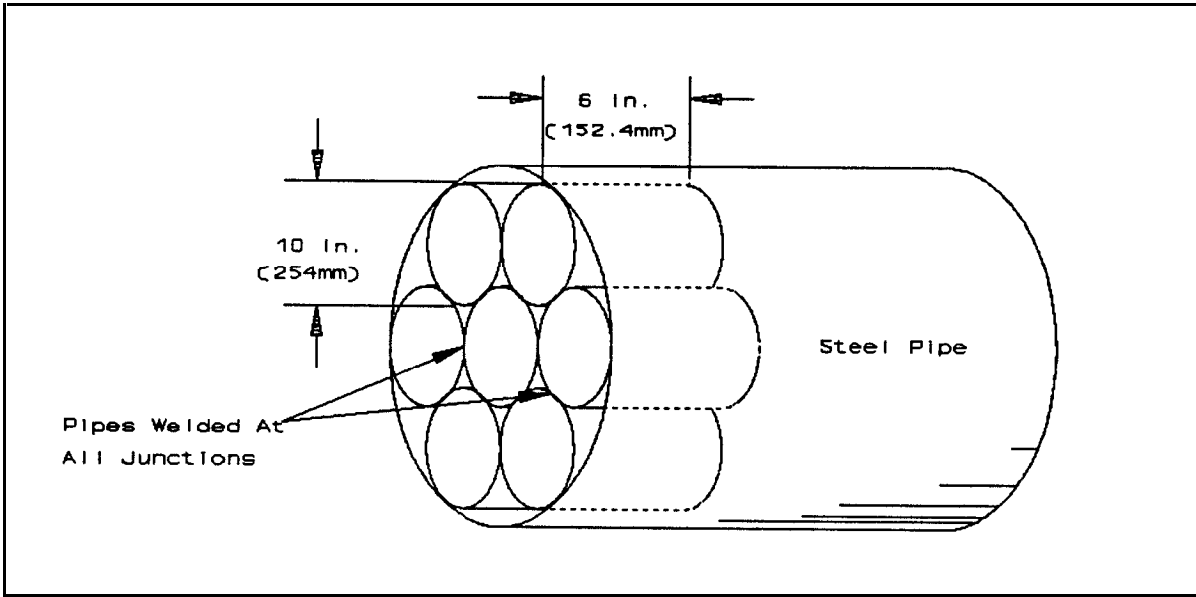

Figure 5.
Large Culvert with Short Honeycomb Pipes.

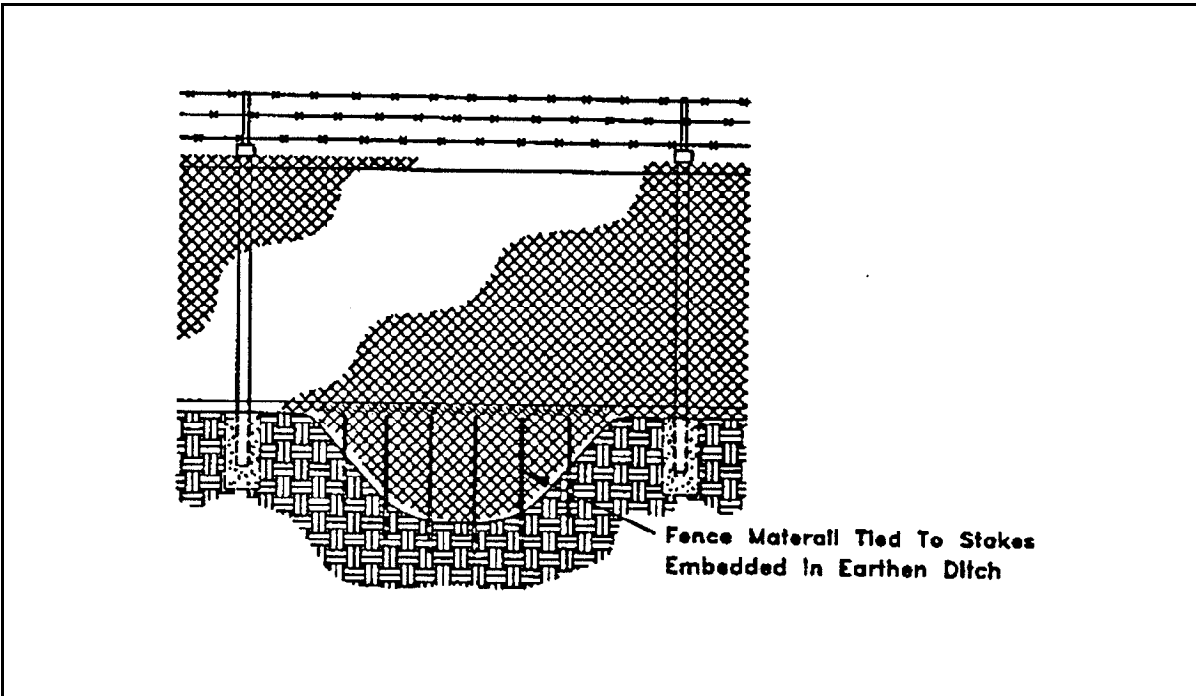

Figure 6.
Swale Crossing with Ground Stakes.

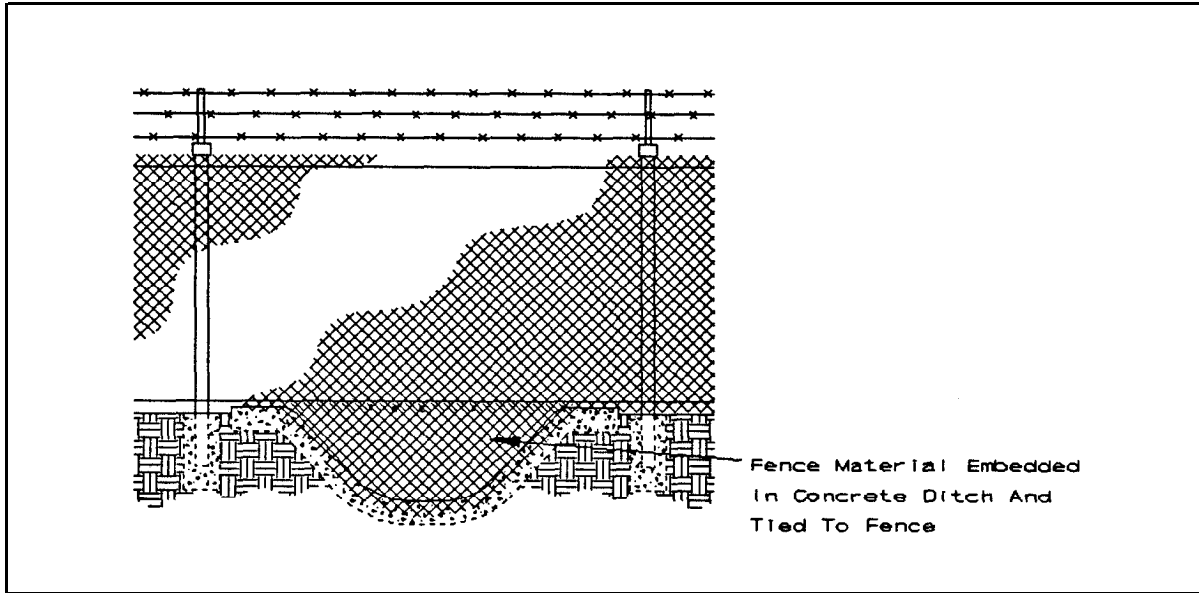

Figure 7.
Swale Crossing Embedded in Concrete.

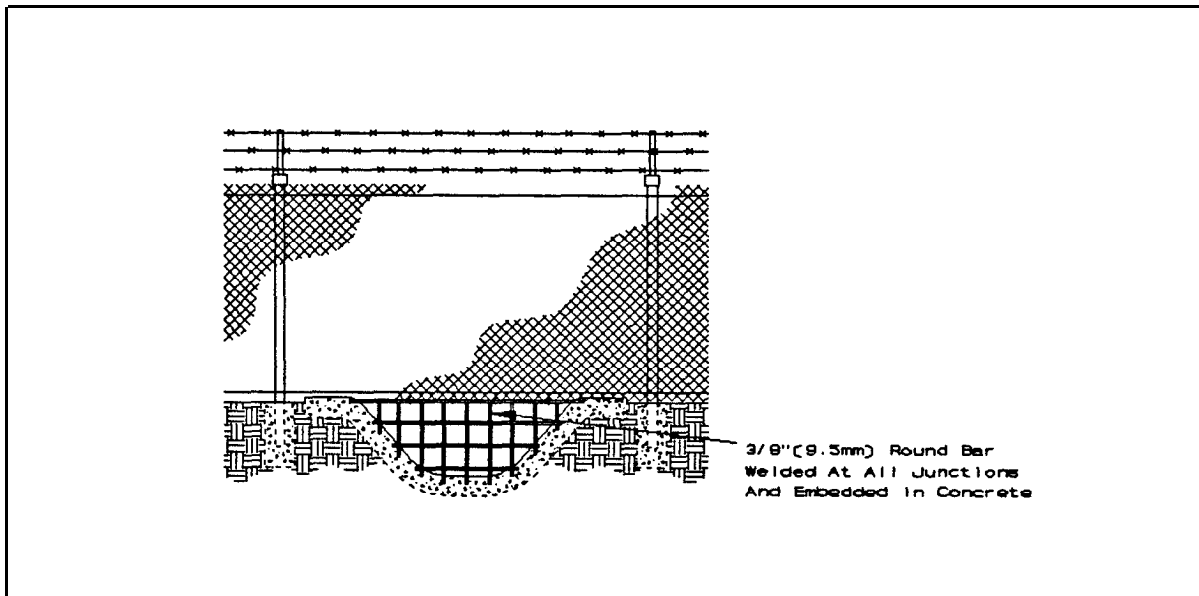

Figure 8.
Bar Grill Embedded in Concrete.

MIL-HDBK-1005/3, Drainage Systems, provides considerable information concerning design criteria and planning guidelines for drainage systems. While this guidance should be utilized to design drainage for the restricted area, the designer must assure the security aspects of the design take precedence over the drainage guidance contained in the MIL-HDBK.

2.3.6.6 Tunneling. A soils engineering analysis should be made where soft or shifting soil, such as sand, is encountered. Since the penetration resistance of a security fence approaches 15 seconds, the year-round soil condition at the facility must also provide 15 seconds as a minimum of tunneling resistance. Where the soil analysis indicates tunneling can be accomplished in less than 15 seconds, the fence will be embedded in a continuous concrete curb. The recommended depth of the curb will be determined from the soil analysis and the frost line at the facility.

Since the entire fence line at nuclear sites is embedded in a continuous concrete curb, as shown in Figure 9, tunneling should be prevented except in the most severe cases of shifting sand. At nuclear sites with very sandy terrain, a soils engineering analysis should also be made to determine the recommended depth of the concrete curb. When specifying the depth of the concrete curb and concrete embedded fence poles, the designer should also consider the frost-line for the subject area to assure that heaving of the posts and curb cannot occur during the winter.

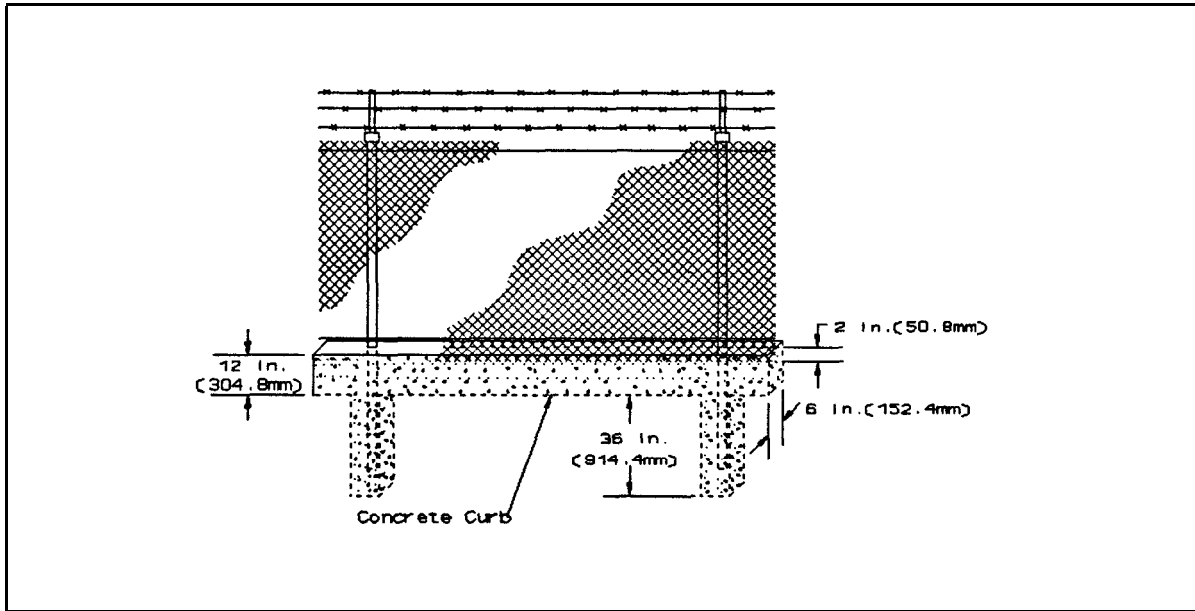

Figure 9.
Chain-Link Fence Embedded in Concrete Sill.

2.3.7 Maintenance Considerations. Consider the following when designing chain-link fencing:

a) Fence components may require additional protective coatings in salt-laden and highly corrosive areas, e.g., plastic coating over galvanized steel fabric.

b) Rapid growth of vegetation in fertile areas and rainy climates may justify paving the area under the fence and a portion or all of the clear zones.

c) Consideration should be given for equipment, i.e., mowers, tractors, etc., required to maintain vegetation below 8 inches (203.2 mm) and to broadcast defoliants or sterilants.

2.3.8 Erosion Control. For erosion control, refer to MIL-HDBK-1005/3, Drainage Systems and NAVFAC DM-5.14, Groundwater Pollution Control. Where erosion control measures advised in either MIL-HDBK-1005/3 or DM-5.14 violate the security requirements contained herein, the security requirements take precedence.

2.3.9 Grounding. Generally, grounding is not required for chain-link fences mounted on metal posts. However, fences shall be grounded on each side of every gate, at points 150 feet (45.7 m) on each side of high-tension line crossings, and at 150-foot (45.7-m) intervals along the fence where high-tension lines (as defined by ANSI C2) are directly overhead and run parallel to the fence. Fences shall be grounded every 1,000 feet to 1,500 feet (304.8 m to 457.2 m) of length when fences are in isolated places and at lesser distances depending upon proximity of fence to public roads, highways, and buildings. Grounding will also be provided for fenced conventional AA&E and nuclear weapons storage areas. The ground shall be made with a bolted connection at a fence post by the use of No. 2/0 AWG (67.4 sq mm) copper cable. Where plastic coated fabric is used, the post shall be bolted, and each strand of the fence shall be brazed to the metallic bare conductor. The conductor shall then be grounded. For additional information, see MIL-HDBK-1004/6, Lightning Protection.

2.4 Special Requirements for Fences Equipped with Intrusion Detection Systems (IDS) Sensors. IDS sensors are often placed on security fences and clear zones to detect aggressors attempting to gain access to an asset. Exterior sensors consist of four major types of field sensors: beam sensors, fence disturbance sensors, seismic sensors, and video motion detectors. If exterior IDS sensors are to be included in the fabrication and installation of security fences, the criteria presented in DM-13.02, Commercial Intrusion Detection System (IDS) should be used.

2.4.1 Taut-Wire Fences. Taut-wire sensed fences may be installed around designated restricted areas, except for AA&E and nuclear restricted

areas, when IDS sensors are desired to increase the detection capability of the security force.

Taut-wire sensed fences will be 7 feet (2.1 m) high and have a 31-inch (787.4-mm) double outrigger equipped with sensor devices. The sensor system shall consist of horizontal barbed wire spaced approximately 4 inches (101.6 mm) apart and connected to a central detection device tensioned between two anchor devices. Before designing taut-wire sensed fences, Naval Electronic Systems Engineering Center (NAVELEXCEN) should be contacted for the latest installation specifications.

2.4.2 Special Requirements. In order to maintain optimal performance for electromechanical fence sensors, it is imperative that the chain-link fence be well constructed with tight tensioning maintained throughout the fence line. The fence construction must be adequate to support the added weight of the IDS. This type of sensor requires frequent fence maintenance.

For additional details and information concerning fence design requirements for specific fence IDS systems, contact NAVELEXCEN, Code 33, at DSN 563-2030, commercial 803-745-4600 or write:

Naval Electronic Systems Engineering Center
Code 33
4600 Mariott Drive
Charleston, SC 29418-6504

2.4.3 IDS Funding. MILCON funds cannot be used for design or construction of IDS. MILCON projects may include fence IDS systems funded by the customer.

2.5 Penetration-Resistant Barriers. Recent terrorist incidents involving the use of suicide-type crash entry forces the consideration of vehicle barriers capable of stopping large vehicles traveling at high speed.

Crash tests of chain-link fences, similar to the chain-link fence required by this handbook, allowed full penetration with no personnel injuries of both a 1-1/2-ton (1360.7-kg) and 2-ton (1814.4-kg) vehicle traveling at 50 miles per hour (80.5 km per hour). An analysis of crash test data indicates that, unless enhanced by the addition of cables, fences offer little protection against penetration. Consequently, to meet a vehicle threat, fence reinforcement measures may be required to maintain security of a restricted area. Crash tests performed on a chain-link fence reinforced with a 3/4-inch (19.1-mm) aircraft cable restricted penetration of a 2-ton (1814.4-kg) vehicle traveling at 50 mph (80.5 km/h) to 26 feet (7.9 m).

When selecting barriers for penetration resistance, the designer should choose active or passive barriers based on their capacity to stop the threat vehicle at the maximum speed it could attain in its approach.

a) Passive Barriers. Use passive barriers where unmovable barriers are needed, such as along a perimeter chain-link fence.

b) Active Barriers. Use active barriers where vehicles must be allowed passage, but the capacity to stop them must also be maintained.

2.5.1 Reinforcement of Perimeter Chain-Link Fence. A reasonable approach to reinforce a standard chain-link perimeter fence to resist a vehicle attack is both simple and aesthetic. Place a 3/4-inch (19.1-mm) diameter aircraft cable, conforming to MIL-W-83420, along the fence line, between the fence posts and the chain-link fabric as shown in Figure 10. Fasten the cable with 1/2-inch (12.7-mm) U-clamps (SAE Grade 3 or better) at a height of approximately 30 inches (762 mm) from ground level. Terminate each cable end with either three wire rope clamps (MS16842) or a wire rope hydraulically swaged press fitting (MIL-P-80104). The cable end will be attached to one end of a 3/4-inch (19.1-mm) round turnbuckle (MS51561) with double eye ends which in turn will be attached to the deadman eyebolt (MIL-B-45908) by a 3/4-inch (19.1-mm) anchor shackle (SAE Grade 8 or ASTM A 490).

The deadman anchor will be a concrete cube, approximately 3 by 3 by 3 feet (1 by 1 by 1 m). Eyebolts captured in the deadman anchors will have either a welded "T" or "L" end embedded in the concrete as shown in Figure 11. As a minimum, 2 feet (0.610 m) of the eyebolt and its welded extension will be captured within the concrete of the deadman. The shaft of the eyebolt will be either in-line with the attached cable or the eye of the eyebolt will be flush with the surface of the deadman. Anchors shall be placed at a minimum of 200-foot (60.9-m) intervals and a maximum of 1,000-foot (304.8-m) intervals on the inside of the perimeter fence with the front edge of the deadman flush with the fence fabric. The top of the deadman will be either flush or buried below the surface as long as the eye of the eyebolt is above ground level. Cables must overlap as shown in Figure 10 before terminating at a deadman so that no voids in the cable occur along the perimeter. If additional hardening is desired, a second cable should be placed about 5 inches (127 mm) above the first cable and attached as described above. It may be anchored to the same deadmen used by the first cable system.

When gates form a portion of the fence line being protected by a vehicle restraint cable system, then the gate cable system described in Section 3 must be interconnected to the fence cable system to ensure continuity of the cable system. Often, natural barriers such as mountains, cliffs, rivers, seas, trees, vegetation, or other terrain protect the fence from vehicle attack. The vehicle restraint cable system should not be used along portions of the fence line that are otherwise protected by natural barriers, such as large boulders, trees, natural ravines, and ditches.

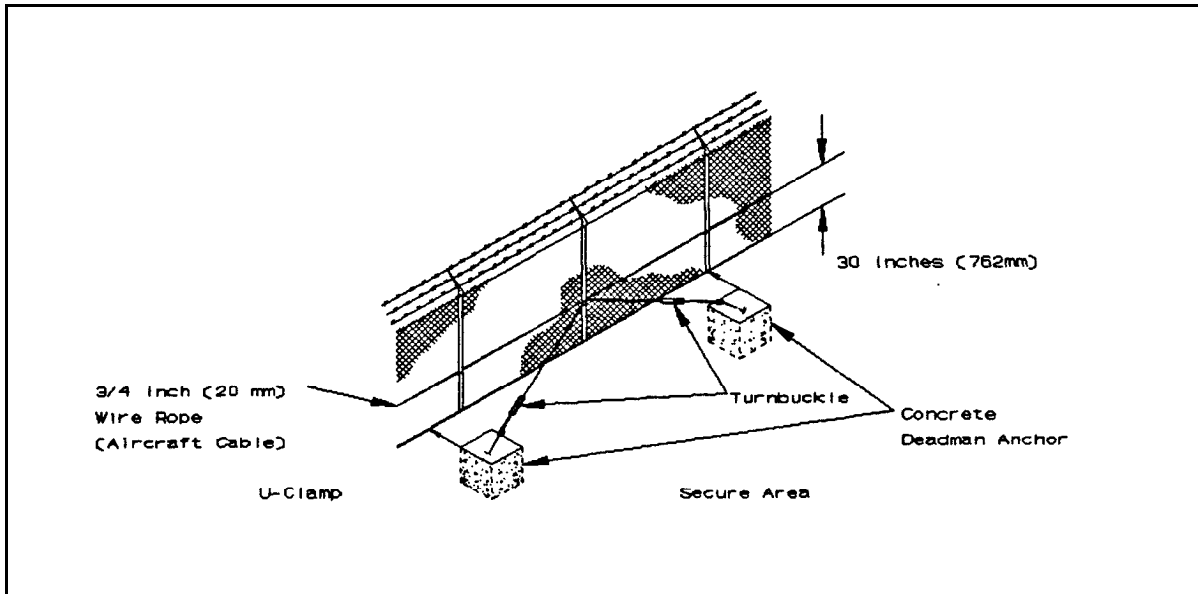

Figure 10.
Steel Cable-Reinforced Chain-Link Fence.

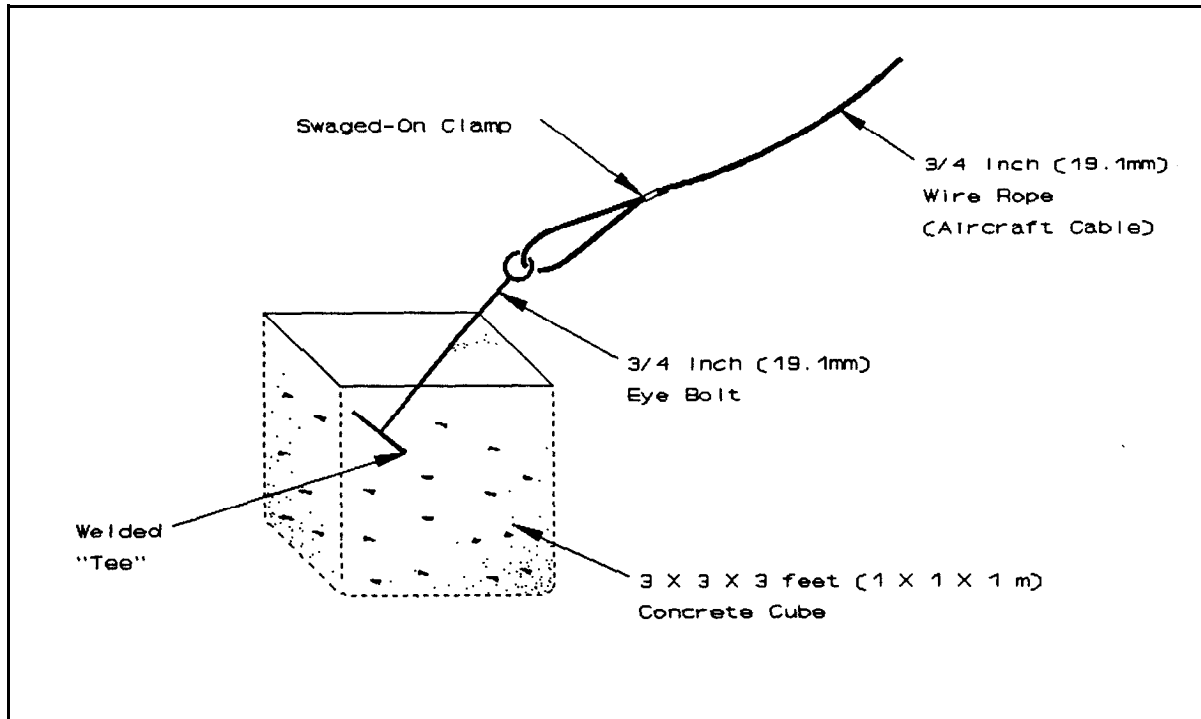

Figure 11.
Deadman Anchor.

2.5.2 Additional Barriers. Alternatives to the barriers listed above, along with a decision tree for vehicle barrier selection and design criteria, can be found in the NCEL Terrorist Vehicle Bomb Survivability Manual, July 1988. Many of the passive barriers contained in the manual may be more convenient, suitable, or economical to install than the fence cable vehicle restraint system. The fence location should drive the actual selection of a barrier or barrier system. Some examples of active and passive vehicle barriers are:

- a) Active (pop-up) type vehicle barriers.
- b) Both active ("pop-up") and passive bollards.
- c) Across-the-road bar-type barriers.
- d) Dragnet systems.
- e) Concrete planter boxes, jersey bounces, anchored concrete median barriers.
- f) Buried heavy equipment tires.
- g) Concrete and concrete block walls.
- h) Sand filled 55-gallon (208.2-liter) drums.
- i) Highway-type guard rails and cable systems.

Section 3: GATES

3.1 Application. Gates facilitate control of authorized traffic and its flow. They establish specific points of entrance and exit to an area defined by fences. They also function to limit or prohibit free flow of pedestrian or vehicular traffic, while establishing a traffic pattern for restricted areas.

3.2 Related Criteria. Gates, as a part of perimeter fences, must be as effective as their associated fence to provide an equivalent deterrent. Gates will normally require additional hardening features due to their location across entrance roads and the inherent vulnerability of their hinges and latches. Gates are known to be the weakest point in the perimeter security fence and as such, you must pay attention to their requirements when designing security fencing.

Materials used in fabricating and erecting chain-link gates must be the same as the materials used for the associated chain-link fence. As for security fences, **aluminum pipe, poles, fabric, or accessories will not be used or specified for security gate components.** Use American Society for Testing and Materials (ASTM) standards to supplement Federal specifications when further detail or criteria is desired.

3.3 Types of Gates. Federal Specification RR-F-191/2 is the basic criteria document for security fence gate design. It provides specifications for the following eight types of chain-link fence gates:

- a) Type I - Single Swing Gates.
- b) Type II - Double Swing Gates.
- c) Type III - Single Cantilever Sliding Gates, Wheel Sliding Gates.
- d) Type IV - Double Cantilever Sliding Gates.
- e) Type V - Single Overhead Sliding Gates.
- f) Type VI - Double Overhead Sliding Gates.
- g) Type VII - Vertical Lift Gates.
- h) Type VIII - Special Gates.

The gate types listed above are the most common gate configurations used for security fencing. These include single and double swing gates (Figures 12 and 13), single and double cantilevered gates (Figures 14 and 15), wheel-supported (V-groove) sliding gates (Figure 16), and single

and double (biparting) overhead supported gates (Figures 17 and 18). While any of these may be used for pedestrian or vehicular traffic, generally single gates will be designed for pedestrian traffic and double gates for vehicular traffic.

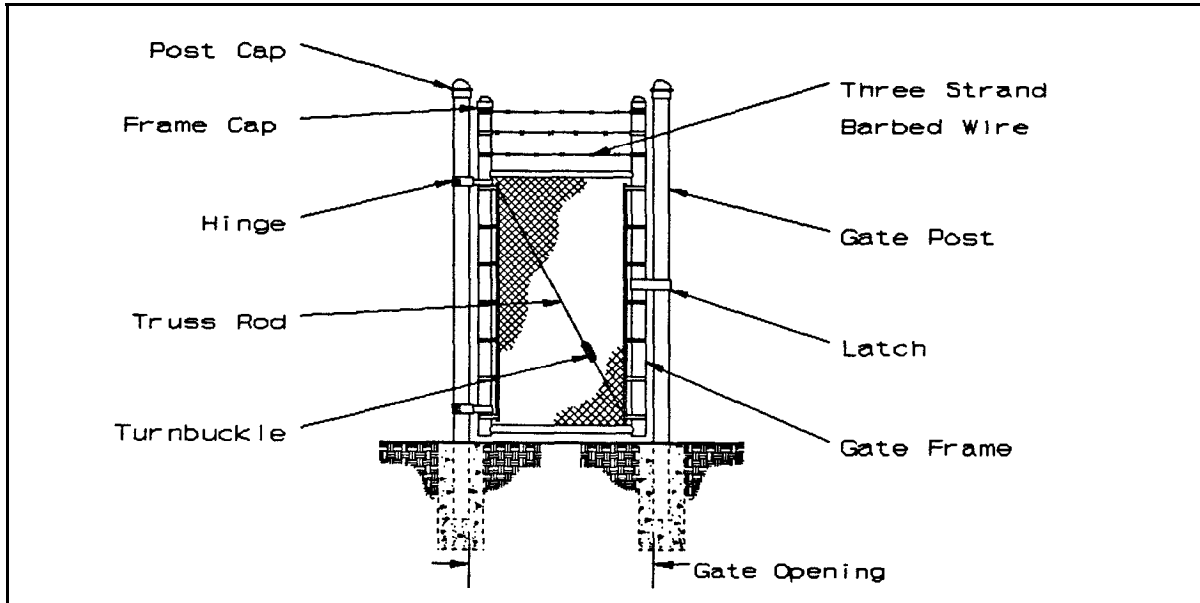

Figure 12.
Single Swing Gate.

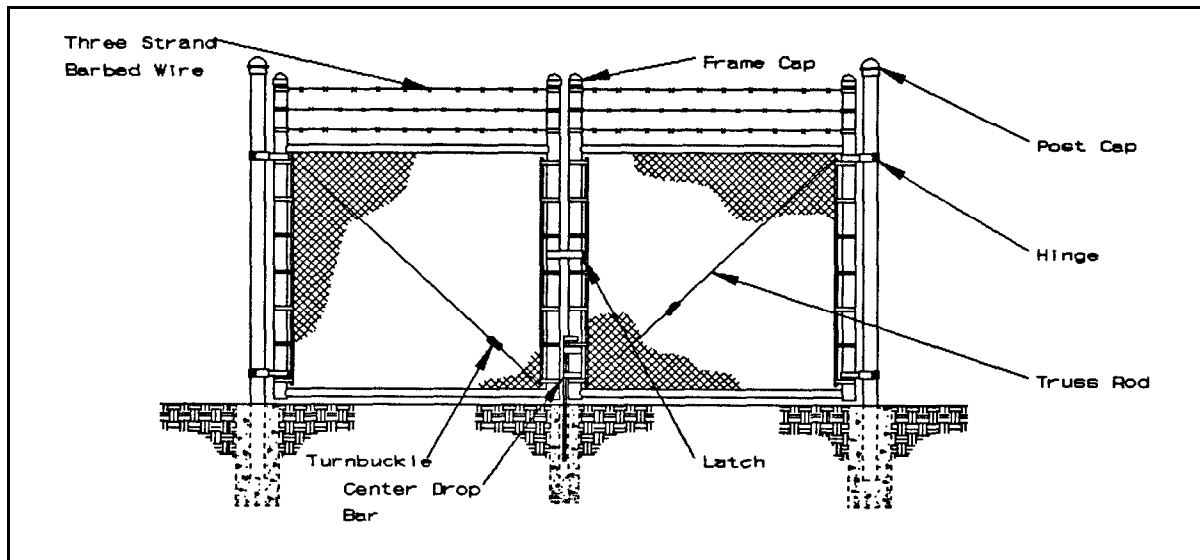

Figure 13.
Double Swing Gate.

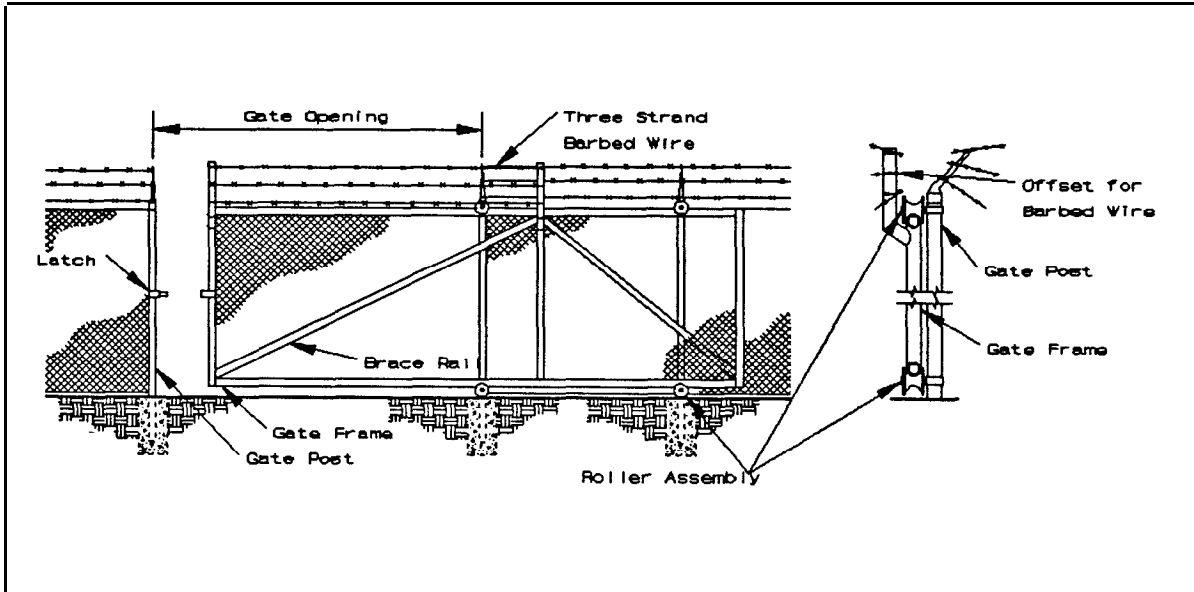

Figure 14.
Single Cantilevered Gate.

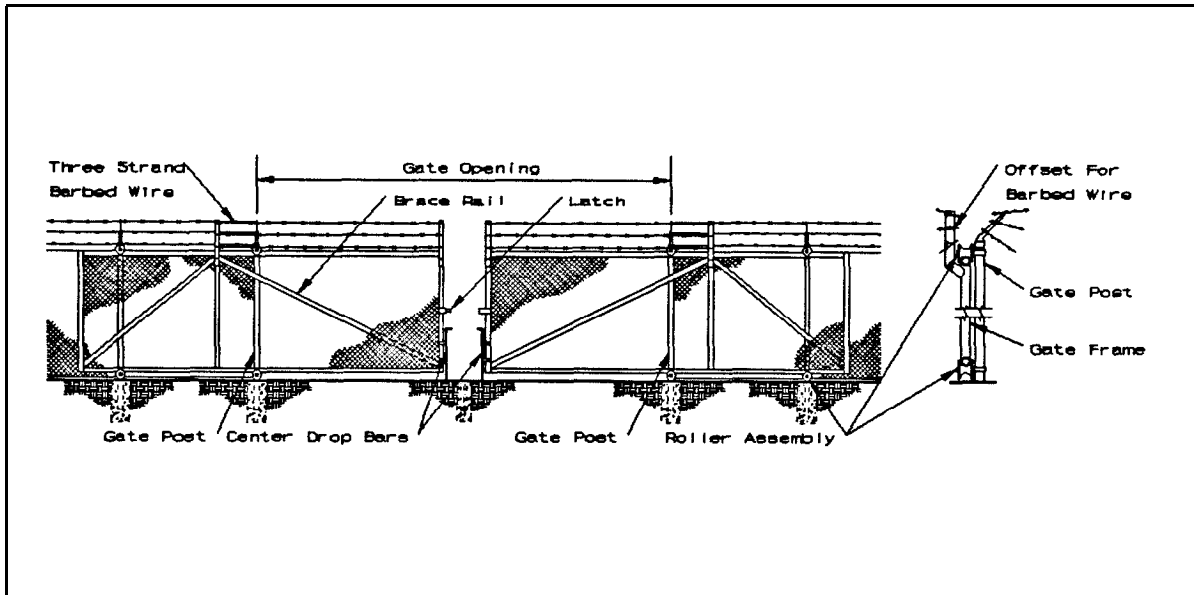

Figure 15.
Double Cantilevered Gate.

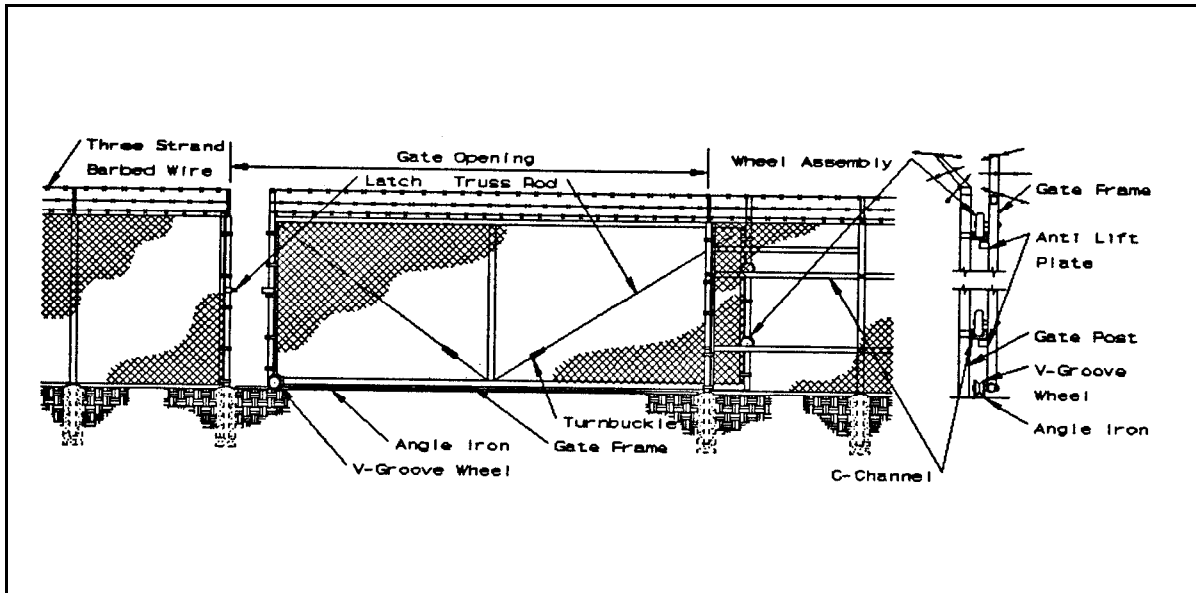

Figure 16.
Single Wheel-Supported (V-groove) Sliding Gate.

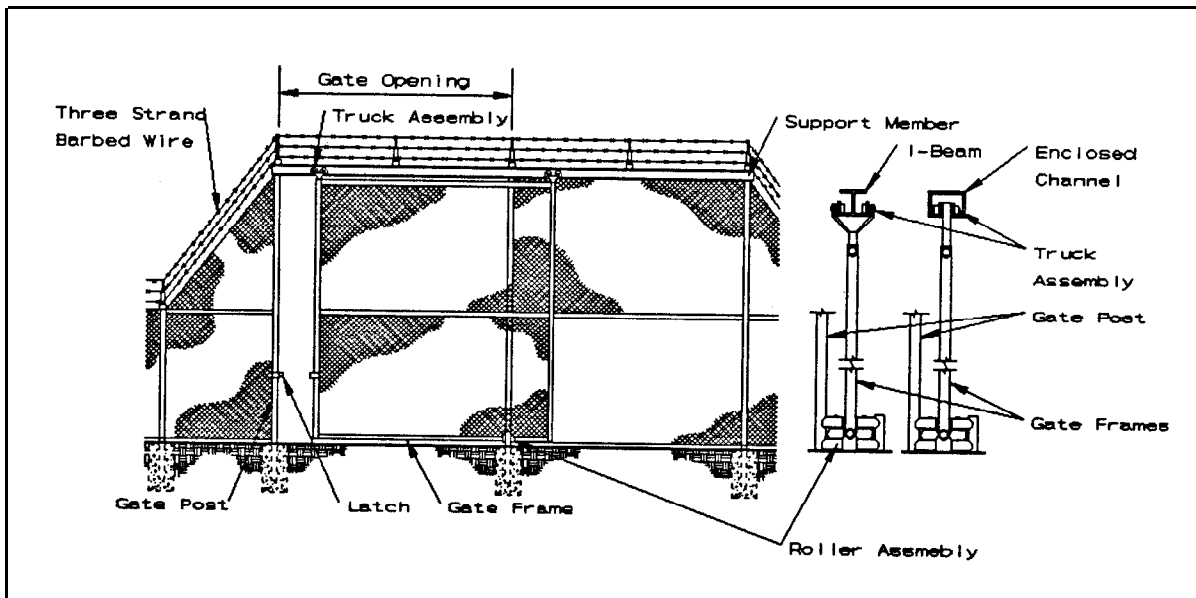

Figure 17.
Single Overhead Supported Gate.

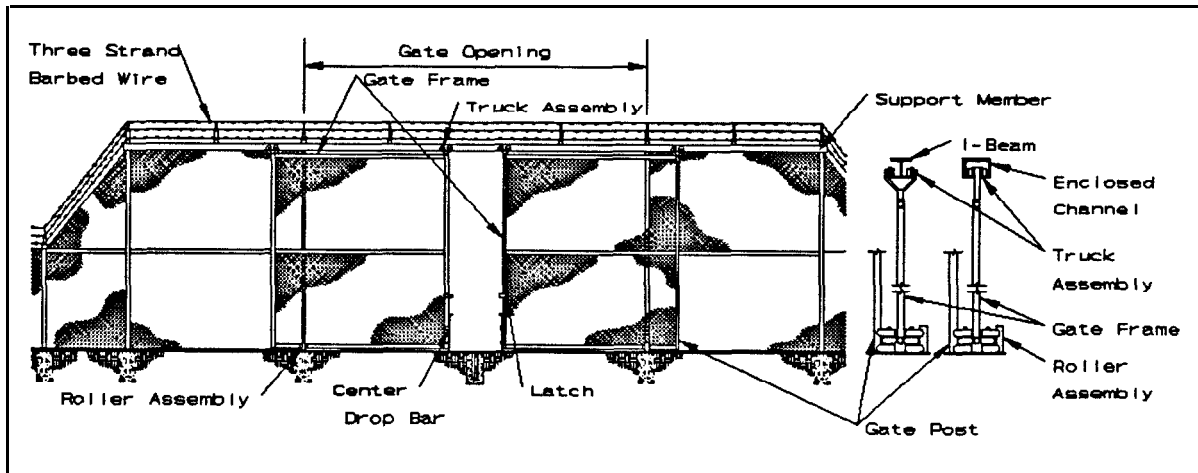

Figure 18.
Double Overhead Supported (Biparting) Gate.

The vertical lift gate (not shown), often referred to as a "guillotine" gate, is not desirable and should only be used under extremely unusual circumstances. Special gates, such as turnstile (rotational) gates (Figure 19), are designed either for specific purposes or to accommodate unusual circumstances.

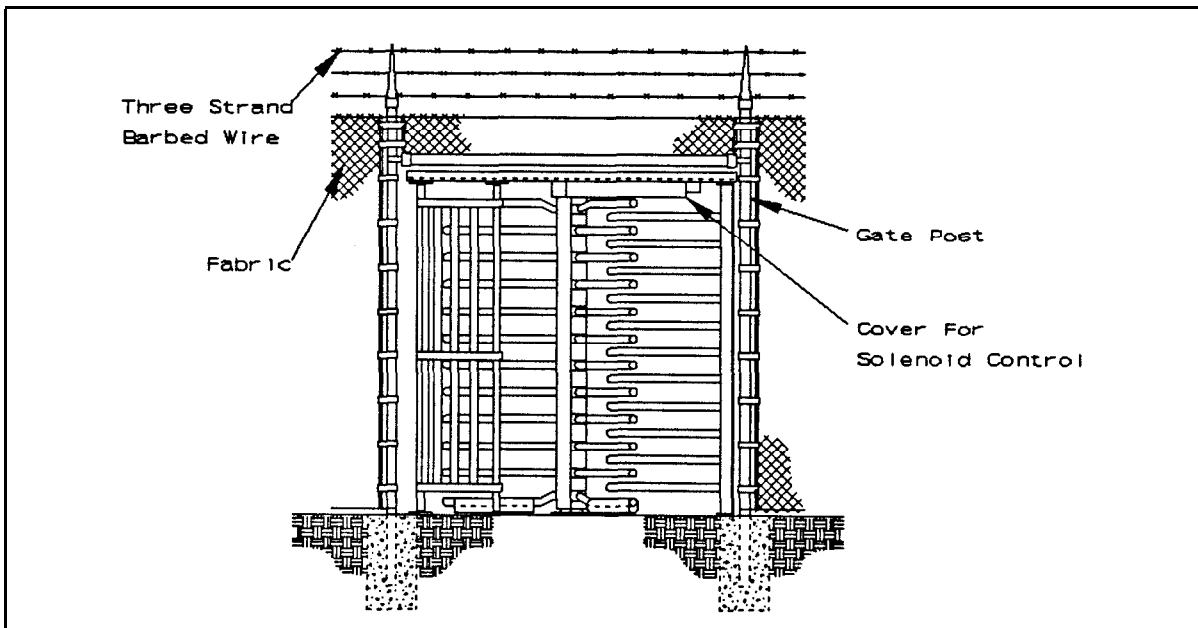

Figure 19.
Turnstile (Rotational) Gate.

3.4 Design. All chain-link gates must conform to Federal Specifications RR-F-191/2. Gate accessories must conform to RR-F-191/4. The designer may use ASTM F 900, Specifications for Industrial and Commercial Swing Gates, to augment Federal specifications where appropriate. The width of the gate opening should be kept to a minimum consistent with the actual requirements for controlled passage of pedestrians or vehicles. A primary concern for gate design associated with security fences is to assure the bottom of the gate fabric extends within 2 inches (50.8 mm) of the roadbed or firm soil when closed. Where possible, pedestrian and vehicular gates should be clearly separated and defined.

3.4.1 Selection of Gate Type. Conduct a thorough study of the terrain in the general vicinity of a proposed gate to determine the most suitable gate type and design for that specific location. Review the site survey and access control plan during the gate selection process. Basically, there is little security difference between gate types. While there are a number of factors to consider in selecting the proper gate for a security fence, the designer will find that terrain and operational aspects are the driving forces in gate selection.

For overhead supported and vertical-lift gates, the designer needs to provide additional protection for the upright posts, protruding above the nominal fence height, that can be used as an advantage by an intruder. Gates for security fences are provided for two basic purposes - personnel and vehicle access.

3.4.1.1 Personnel Gates. Where access control is required into a restricted area, turnstile gates are recommended for controlling pedestrian traffic as shown in Figure 19. Turnstile gates are also very helpful in relieving guard requirements for controlling personnel exiting a secured area since they can be set to revolve only in the exiting direction thereby reducing guard supervision required. Automated access control systems using coded credentials such as badges with magnetic stripe, magnetic spot, proximity, Wiegand effect wires, etc., may also be used to access turnstile gates. When automated access is desired, NAVFAC DM-13.02 should be consulted for specific information concerning these access control systems.

While turnstile gates provide security personnel with more positive access control and greater penetration resistance, swing gates are a second alternative when turnstile personnel gates are not practical. Swing type personnel gates may be more economical to procure and fabricate from a hardware aspect. However, both operational and guard personnel requirements should be considered to determine the most economical long-term cost for the facility.

Pedestrian gates and turnstiles will be designed so that only one person may approach the guard at a time.

For nuclear storage areas, the personnel entry gate complex, to include access and exit routes, will be designed in accordance with NAVFAC P-272, Definitive Drawings, drawing number 1404126.

3.4.1.2 Vehicle Gates. Either wheel-supported or cantilever sliding gates are the best selection for vehicle security gates followed by overhead sliding gates. Swing gates are a third alternative and lastly, by far the least desirable, are overhead ("guillotine") gates. Initially, the designer should begin by evaluating the wheel-supported or cantilever sliding gate. An initial step in the design is to determine the operational requirements for the gate. Determine the daily peak and normal work flow of vehicles. Ascertain the operational access control requirements for the secured area, i.e., badging, penetrator threat, magnetic sensor personnel monitoring, package surveillance, type (size) of vehicles to use the gate, etc. These details will lead to determining the type and size of gates, desirability or requirement for automatic openers, special hardening requirements, etc. In areas known for snow or ice buildup, internal heating should be considered in the gate design.

3.4.1.2.1 Sliding Gates. Sliding gates, when open, store parallel to the adjacent fence line, unlike the large sweeping arc that swing gates require. When designing the roadbed at the gate opening, the surface should be kept as straight as possible, allowing for drainage by a slight incline to one side or the other of the entire roadbed. When an existing road surface is encountered that is not essentially flat, the designer should require asphalt or concrete fill to level the roadbed where the gate will be installed.

The cantilever gate design, (Figures 14 and 15), provides full support and suspension of the gate frame by four rollers secured to two posts inside the restricted area. Since the required length of a cantilever gate is 1-1/2 times the size of the opening, there must be a straight, and essentially level, fence line adjacent to the gate to accommodate this length when the gate is fully open. Cantilever gates can compensate for a somewhat crowned or unlevel roadbed and do not require a "V"-bar guide rail or trough across the roadbed. Cantilever sliding gates are not recommended for openings exceeding 24 feet (7.3 m), although two biparting sliding cantilever gates can be used for openings up to 48 feet (14.6 m).

Wheel-supported gates (Figure 16) for security fences require either a guide rail ("V"-groove) or trough across the roadbed. With the "V"-groove design, the gate's leading edge utilizes a wheel that has a deep groove cut into its outside circumference. This wheel travels on inverted angle iron that is secured across the roadbed on the ground. The rear of the gate travels with two wheels riding in "C" channels as shown in Figure 16. The trough design utilizes a metal wheel with a convex diameter that rides down in a groove extending across the roadbed. While the trough provides a smoother surface for vehicular traffic, it is not recommended due to typical debris buildup in the groove causing the wheel to ride up out of the groove onto the roadbed surface. In both styles, the upper portion of the gate is supported

laterally by additional vertical rollers. Since wheel-supported gates are not cantilevered, they only need to be somewhat longer than the actual size of the gate opening, requiring one-third less straight and level storage length along the fence line than the cantilever gate. Wheel-supported gates essentially are not limited in the size of their opening except for the power requirements of the gate operator. A variation of the wheel-supported gate is one using dual pneumatic, hard rubber, or steel wheels to support the gate. These can be identified by their lack of roadbed guides. They should only be used as a last resort, and then only for manually opened sliding gates.

3.4.1.2.2 Overhead Gates. Overhead gate design requires either an I-beam or an enclosed track (Figures 17 and 18), suspended over the width of the opening and extending an equidistance on one side or the other of the gate opening to store the gate when it is opened. Similar to wheel-supported and cantilever gates, the gate must store parallel to the adjacent fence line. The gate storage area must be in line with the gate opening and either be level or have a decreasing grade to accommodate the gate when it is fully open. The gate is suspended from the I-beam or enclosed track by a pair of rollers attached to posts extending upward from the leading and trailing edge of the gate. The overhead beam or track height must allow clearance for anticipated truck or rail traffic. The gate will be suspended above the ground from the overhead beam or track and supported laterally near the ground by vertical rollers. The enclosed track design incorporates the best of the overhead gate designs, and is well suited for automatic operators. The tracking system provides the convenience of a wheel-supported or cantilever-type installation, but with a much more efficient means to roll the gate. The amount of force to operate gates with these designs is significantly less than that of comparable gates. High-cycle demands, large opening sizes, or heavy gate construction may require strengthening the overhead I-beam design. Additional upright posts extending upward from the center of the gate will also allow the enclosed track to carry heavier loads.

3.4.1.2.3 Swing Gates. Swing gates (Figures 12 and 13) should be designed so that they swing inward, toward the secured area. The disadvantage of the swing gate is the large arc of space required for operation. Swing gates can either be designed to swing 90 degrees inward and 90 degrees outward or swing 180 degrees inward only. An important consideration in selecting a single or double swing gate design is maintaining clearance along the bottom of the gate as it swings through its arc from the closed to the open position. If the grade is increasing inside of the gate, grading will be required to allow clearance. The required 2-inch (50.8-mm) maximum clearance between the bottom of the fence and the roadbed must be maintained when the gate is in the closed position.

The swing gate design places considerable weight on the hinge post and its foundation. The longer the gate, the more load (moment arm) placed on the gate post. ASTM F 900 provides design detail for single swing gates up to 24 feet (7.3 m). Ideally, single swing gates should not exceed 14 feet (4.3 m) and double swing gates should not exceed 28 feet (8.5 m). Since the weight of

the gate must be borne by the gate post, design of the gate post and its foundation is critical to assure proper support of the swing gate. An undersized or improperly installed gate post may shift and cause the gate to move out of plumb with the ground. This may cause the gate to drag on the ground or change elevation as the gate moves through its arc from the opened to closed position. Table 1 provides recommended concrete foundation diameters for swing gate posts. As a minimum for swing gate posts, the concrete foundation should be 3 feet (1 m) deep.

Table 1.
Gate Post Foundations.

STEEL POST DIAMETER	FOUNDATION HOLE DIAMETER	GATE LEAF LENGTH
2.875 in (73 mm)	18 in (450 mm)	0 - 6 ft (0 - 1.8 m)
4.000 in (101.6 mm)	24 in (609.6 mm)	6 - 12 ft (1.8 - 3.7 m)
6.625 in (168.3 mm)	36 in (914.4 mm)	12 - 18 ft (3.7 - 5.5 m)
8.625 in (219 mm)	40 in (1016 mm)	18 - 24 ft (5.5 - 7.3 m)

3.4.1.2.4 Vertical Lift Gates. Vertical lift ("guillotine") gates should only be used when the gate location is mandated, the site is so restricted, or the weather is so severe, that a gate must be placed in such a location where the only way to open it is upward. Vertical lift gates should never be considered except as a last possible design choice. When a vertical lift gate is required, a counterweight with a continuous drive chain on each side (that pulls the gate both up and down) must be specified.

3.4.2 Hinges. The weight, size, and frequency of use are important factors in the selection of gate hinges. Specific design guidance is not contained in the military specification or associated ASTMs. Gate hinges must have adequate strength to support the gate and have large bearing surfaces for clamping them into position. Commercial hinges manufactured to fit increasing diameters of gate posts also have increased mass and capability to support larger swing gates and generally will be found acceptable. The hinges must be secured to the gate post and the gate frame to assure they will not twist or turn under the weight and action of the gate. Welding is recommended. Gate hardware must conform to RR-F-191/2. ASTM F 900 may be used to supplement the military specification. Hinges must be tamper-proof by the addition of welded security plates or by reversing the direction of the hinge pins (one up, the other down), thereby protecting the gate from being lifted off. Bolts and other hardware associated with gate hinges must be welded or peened to prevent their removal by hand tools.

3.4.3 Locking System. Gates will be provided with locking hardware conforming to RR-F-191/2. The locking system is designed to provide an equal level of penetration resistance when a gate is closed and locked with an

approved General Field Service Padlock. Where locking hardware is not practicable, 1/2-inch (12.7-mm) chains meeting the requirements of RR-C-271 (Table 2, Type 1, Grade C, Class 1), will be used with an approved General Field Service Padlock.

While automatic latching (locking) devices are required for vehicular and personnel gates at nuclear storage facilities, they also should be considered during any security gate design.

At nuclear weapons storage sites, vehicle entry sally-port(s), personnel swing gates, and turnstiles, each with their associated gate latching systems, will be designed in accordance with NAVFAC P-272, Definitive Drawings drawing number 1404126. These drawings specify vehicle sally-ports that consist of an enclosed area with two vehicle gates. The gates are electrically controlled so when a vehicle enters, the inner gate is closed while the outer gate is open. The outer gate must be closed and latched before the inner gate can be opened to allow the vehicle to enter the restricted area. The design accommodates the reverse procedure for vehicles exiting the restricted area. All pedestrian and vehicle gates incorporate an automatic electrical latching feature when closed. The remotely controlled gates are operated from the Entry Control Point (ECP). An emergency override is provided in the ECP to allow both gates to be opened simultaneously for emergency vehicles.

Many power operators for sliding gates are designed to "lock-up" gate motion by means of an internal friction brake system that engages when the operator is stopped. This type of locking device is not adequate to secure the gate when it is not manned by security personnel; therefore, one of the locking or latching methods discussed above must be provided.

3.4.4 Gate Power-Operators. As noted above, gate power-operators with automatic latching (locking) systems are required for vehicular gates at nuclear storage facilities. With the requirements of access control becoming more sophisticated and involved, the use of power-operators for gates at other types of restricted areas is more compelling for active vehicular security gate operation. The designer should analyze the facility access control procedures and anticipated traffic flow through each proposed vehicular gate. From this analysis, the potential effectiveness of a power-operator in improving access control operations for gates can be evaluated. When vertical lift gates are designed, gate power-operators are mandatory except in rare circumstances when the gate will seldom be used and manual operation of the gate is reasonable.

Gate power-operator controls must be located so they cannot be reached or tampered with from outside the security fence. Most gates will require site-peculiar operating accessories, warning devices, or safety systems in addition to the actual operator. The designer should coordinate the design of gate power-operators with the command safety officer.

3.4.4.1 Gate Power-Operator Design. A manufacturer's design (using similar components), the standard features provided, and optional accessories available are what primarily separates one manufacturer's products from another. Some manufacturers provide a full line of power-operators for gates in all horsepowers, voltages, and phases, while others limit selection to one or two models which may provide inadequate horsepower and improper voltages for the gate being designed. Gate power-operator capabilities are of particular concern when cantilever gates are installed, particularly when the grade increases from side to side of the opening.

3.4.4.1.1 Sliding Gate Power-Operators. Power-operators for sliding gates can generally be associated in three groups based upon their method of operation. These are:

a) Electromechanical Chain Driven - An electric motor drives a series of reduction and worm gears, chains, and sprockets which in turn drive a chain attached to the gate thereby operating the gate.

b) Electromechanical Rack and Pinion - An electric motor, through gear reduction, operates a rack and pinion gear arrangement attached to the gate thereby operating the gate.

c) Hydraulic Compression Rail - An electric motor operates a hydraulic pump which in turn drives two hydraulic motors. The drive wheel mounted on each motor is compressed and runs on opposing sides of a rail (leg of angle iron), with the other angle iron leg attached to the gate to operate the gate.

The hydraulic compression rail gate power-operator is preferred for automating sliding gates at restricted areas. An independent life-cycle cost analysis, conducted by NCEL, indicates that hydraulic compression rail gate power-operators for horizontal sliding gates offer reasonable acquisition cost, low operations and support costs, and the lowest risk to the Government.

3.4.4.1.2 Swing Gate Power-Operators. Power-operators for swing gates can generally be placed in two groups based upon their method of operation. These are:

a) Hydraulic Piston - A hydraulic piston is attached between the gate leaf and an offset post. The piston is extended and contracted to operate the gate.

b) Electromechanical Swing Arm - An electric motor, through gear reduction, operates a primary arm that travels in an arc parallel to the ground. A second arm is attached between the gate leaf and the primary arm thereby operating the gate.

While an independent life-cycle cost analysis for swing gate power-operators has not been made, preliminary analysis indicates that the

hydraulic piston type of swing gate power-operator has a greater degree of reliability, particularly in areas of measurable snowfall. Greater reliability generally relates to lower maintenance cost. With the acquisition cost of swing gate power-operators being comparable, the hydraulic piston type of swing gate power-operator is recommended for swing-gates.

3.4.4.1.3 Gate Power-Operator Peripherals. The means of activating gate power-operators can be as simple as push buttons to open, close, and stop the gate or can be a very complex electronic automated system. The requirements of controlling the motion, direction, braking, and locking of the gate and gate power-operator are increasingly more demanding. Manufacturers can provide many additional features as standard equipment such as "pause to reverse" and "maximum run time." ("Pause to reverse" delays the gate from immediately reversing from an open cycle to a close cycle, thereby avoiding the shock load on the gate power-operator's mechanics; "Maximum run time" prevents the gate power-operator from continuing to run after a preset time if the gate is obstructed.)

Access control must be a primary consideration for the designer when designing gate systems. Access control may be as simple as having a guard physically open a gate to allow access, or as complex as a system that logs the activity of individuals and the time of their access to specified areas by use of a designated code number. Features, devices, and electronic equipment to automate or expedite access control should be considered during the design of power-operated gates.

A number of issues must be addressed before an access control system design can be considered complete. These include pedestrian traffic, reversing devices to keep gates from closing on vehicles, traffic flow, number of open and close cycles, and type of vehicular traffic. The designer needs to analyze the operational site security plan and review the details of his on-site inspection. Next, he should discuss access requirements for the restricted area(s) concerned with the facility Security Officer to determine the degree of access control required. Electronic access control has a very broad spectrum of devices, technology, and capabilities. DM-13.02 should be consulted for specific information concerning electronic access control systems. Additionally, technical guidance may be obtained from the Naval Electronic Systems Engineering Center (NAVELEXCEN), Code 33 at DSN 563-2030 (803-745-4942) or write:

Naval Electronic Systems Engineering Center
Code 33
4600 Mariott Drive
Charleston, SC 29418-6504

The following are several considerations for selecting peripheral equipment to activate gate power-operators:

a) Who will be authorized to activate the operators and where are they located? (Guard in Access Control Point, remote radio control, key switch, push button, card reader?)

b) How will access control personnel communicate with personnel desiring entrance and exit from the restricted area? (Directly, intercom, telephone?)

c) How will the gate be closed after the vehicle has gained entry? (Guard personnel, automatic timer, infrared (IR) beam?)

d) How will the gate be opened and closed to permit vehicle exit? (Guard personnel, IR beam, button or keypad, remote radio control, roll-across sensor, card reader?)

3.5 Number and Location of Gates. Gates will be limited to the very minimum number to support efficient operations. Centers of activity, facility operations, personnel concentrations, as well as vehicular traffic flow inside and outside the restricted area must be analyzed before locating gates. Alternative gates, which are closed except during peak movement hours, may be provided so that heavy traffic flow can be expedited. Whenever possible, alternate gates should be located so that they are under observation of the normal guard force. All gates will be locked to form an integral part of the fence when closed.

3.6 Traffic Control. Traffic control at restricted areas during peak hours must be evaluated for both pedestrian and vehicular access when designing the entry control complex. Vehicular gates for restricted areas must be set back from any public or military roadway to ensure that temporary delays caused by identification checks will not cause traffic hazards. Sufficient space should also be provided to allow for spot checks, inspections, and searches of vehicles without impeding the flow of traffic.

Entry control design must afford maximum security while minimizing delay in the flow of authorized traffic. Figure 20 provides a characteristic entry control arrangement for a restricted area that has a high volume of assigned personnel and visitors to access daily. Inbound visitors and unauthorized vehicles are diverted from the normal flow entering the restricted area. They have the opportunity to either voluntarily reverse their direction and not approach the ECP, or obtain appropriate vehicle and personnel passes to proceed into the restricted area. A second turnaround is provided immediately beyond the ECP, but prior to the remotely controlled restricted area gates, so that security personnel can reverse the direction of vehicles or personnel that arrive at the ECP without proper passes or decals prior to accessing the restricted area. As a final security measure, remotely controlled active (pop-up) vehicle barriers may be provided inside the gates to obstruct forced or high-speed entry into the restricted area. Tire shredders or remotely controlled active vehicle barriers may also be provided

inside the exit gate to slow down or forcibly stop a high-speed entry attack through the exit.

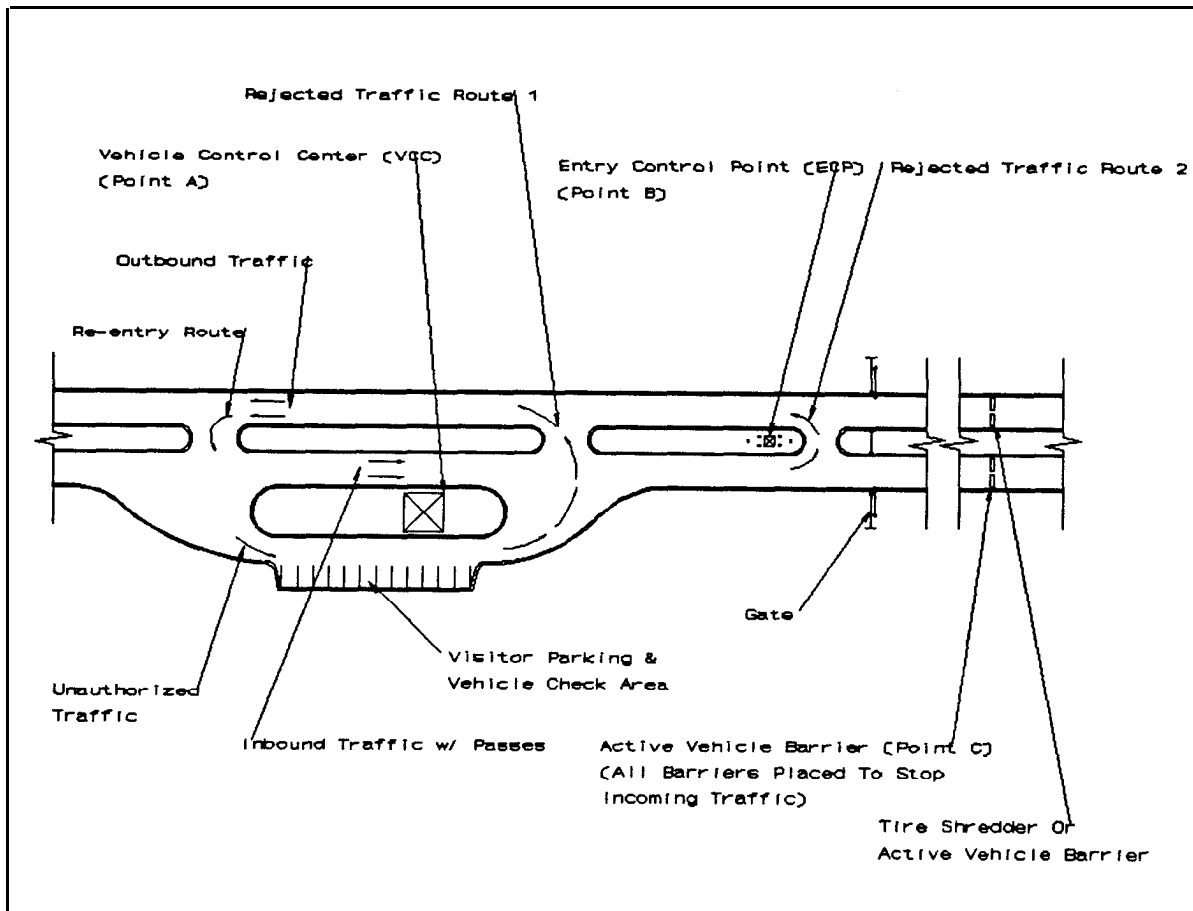

Figure 20.
Entry Control Point Layout.

The ECP shown in Figure 21 represents an entry control arrangement for a restricted area securing critical components but having a low volume of assigned personnel and minimal visitor traffic to access daily. Direct straight-in vehicle access is impeded by a sharp curve and passive vehicle barriers to lessen the possible success of a high-speed vehicle attack. Personnel must pass through turnstiles on foot, one at a time to access the restricted area. Vehicles are processed and inspected in a sally-port area before being allowed to enter or exit the restricted area. Sally-port gates and personnel turnstiles are paired in-line with the direction of entry so that one must be closed and locked before the other of the pair may be opened. Gate opening and locking system overrides must be provided for emergency vehicles. All opening, locking, and emergency controls are contained within the ECP building.

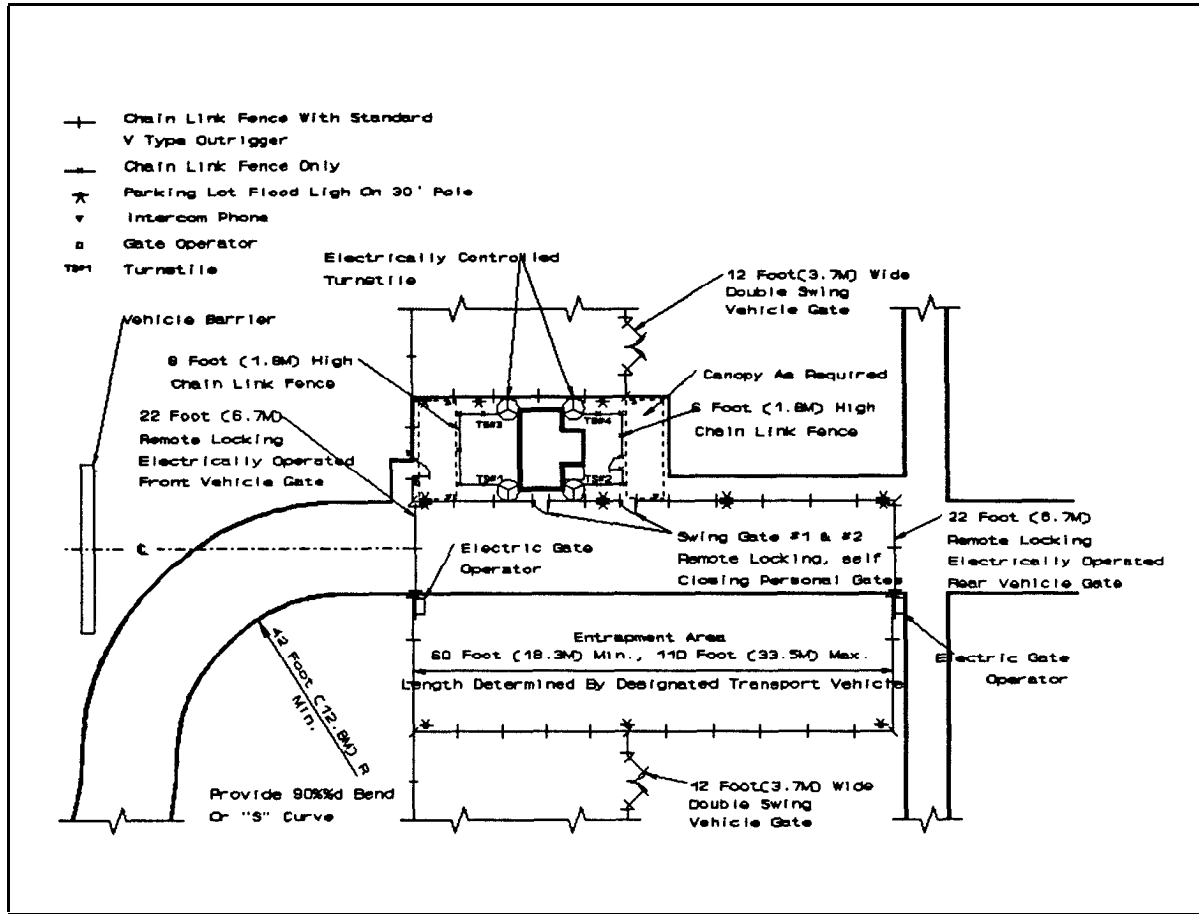

Figure 21.
High Security Site Entry Control Facility.

3.7 Penetration-Resistant Barriers. As discussed in Section 2 for fences, consideration of various vehicle barriers and crash deterrents should be made during gate design. When passive and active vehicle barriers are provided for gates, the fence line must also be hardened along those areas subject to vehicular attack. The designer should refer to the Naval Civil Engineering Laboratory Terrorist Vehicle Bomb Survivability Manual, July 1988, that has been distributed to Engineering Field Divisions and Public Works Centers. This manual not only has considerable detail on many active and passive vehicle crash barriers, but provides a vehicle barrier selection decision tree to aid the designer in selecting and designing appropriate vehicle crash barriers for restricted area gates and adjoining security fences.

3.7.1 Reinforcement of Swing Gates. The locking mechanism and the hinges on a security swing gate are the weakest components of the gate system. These areas can be reinforced by combining chain and wire rope (cable) to form

a barrier across the opening. Once the chain and wire rope has been installed as shown in Figure 22, the energy of a vehicle crash attempt is transferred from the gate through wire rope links to the side gate posts, and further to the fence cable reinforcement system and deadman concrete anchors. The fence reinforcement cable is terminated with a swaged loop around the gate post to interconnect with the gate cable barrier system. With the wire ropes linked together at the fence posts as shown in Figure 23 and chained together at their point of closure as shown in Figure 24, in effect there is a continuous barrier across the opening. The system is simple, unobtrusive, and effective. When the chain is removed, gate leaves can be operated normally without restriction.

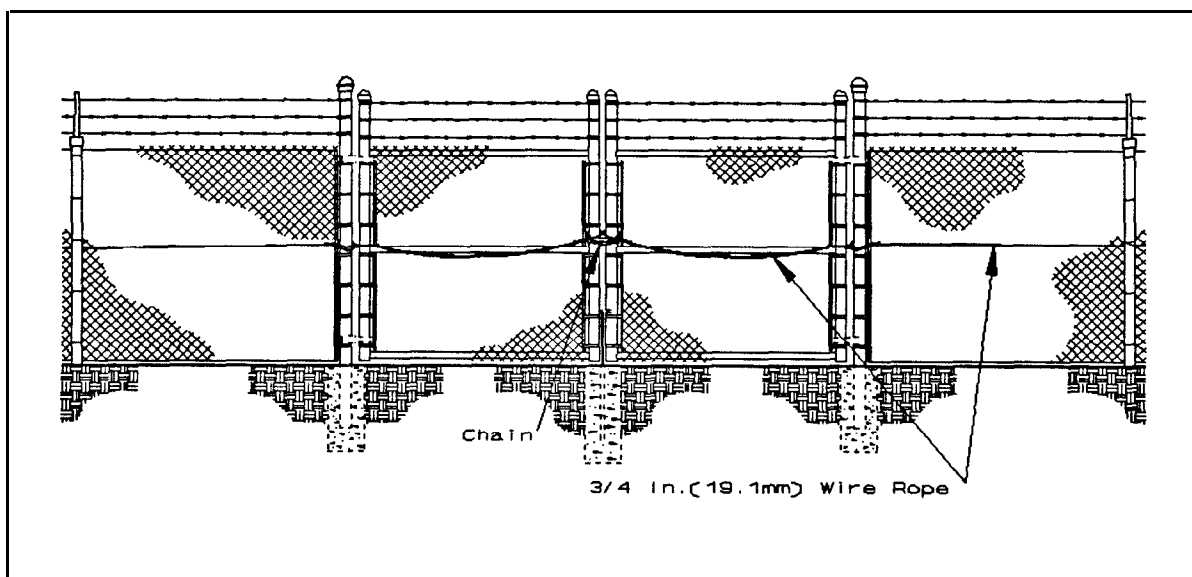

Figure 22.
Chain and Wire Rope Reinforced Gate.

To construct the gate barrier system, a 3/4-inch (19.1-mm) diameter aircraft wire rope, conforming to MIL-W-83420, is looped around the gate post as shown in Figure 23, around the gate frame upright, and through the fence cable loop. The wire rope is strung across the inside of the gate leaf and fastened around the vertical gate frame upright and fabric tension bar midway above the roadbed as shown in Figure 22. Where gates have two leaves involved, a cable will be installed in the same manner on the second leaf. All cable ends are looped and terminated with either three wire rope clamps (MS16842) as shown in Figure 25 or hydraulically swaged wire rope fittings (MIL-P-80104) as shown in Figure 26.

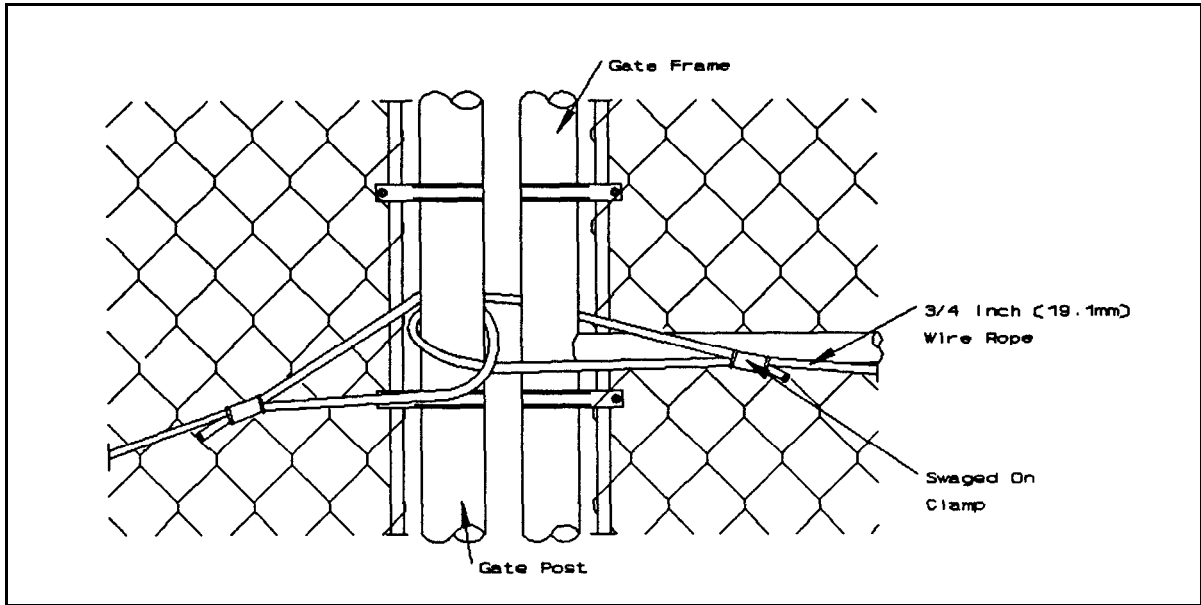

Figure 23.
Wire Rope Interwoven at Gate Post.

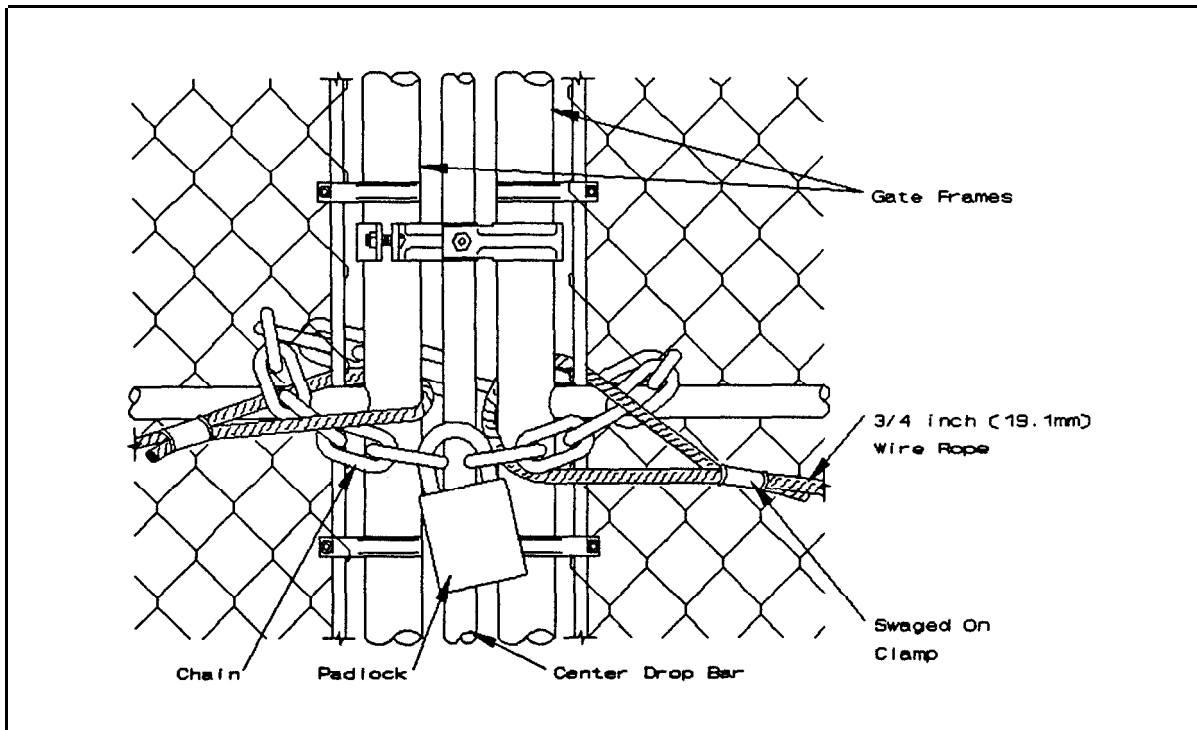

Figure 24.
Chain and Wire Rope Locking System.

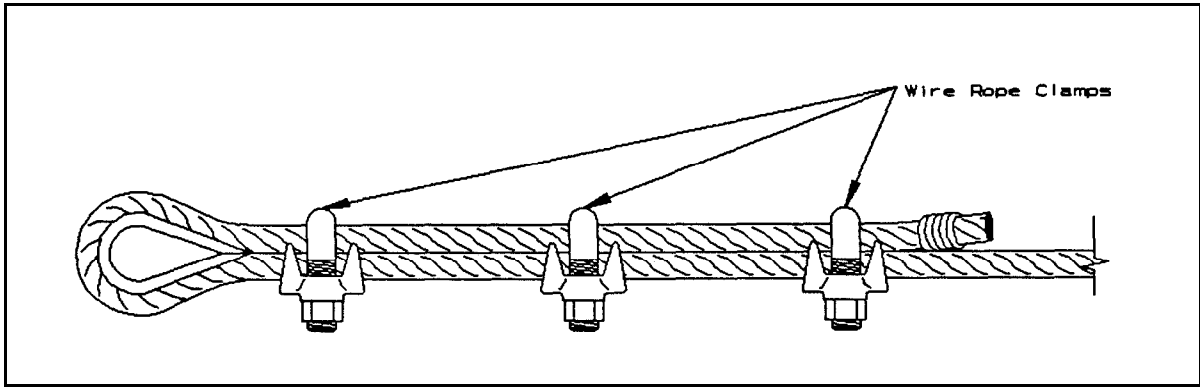

Figure 25.
Wire Rope Clamps.

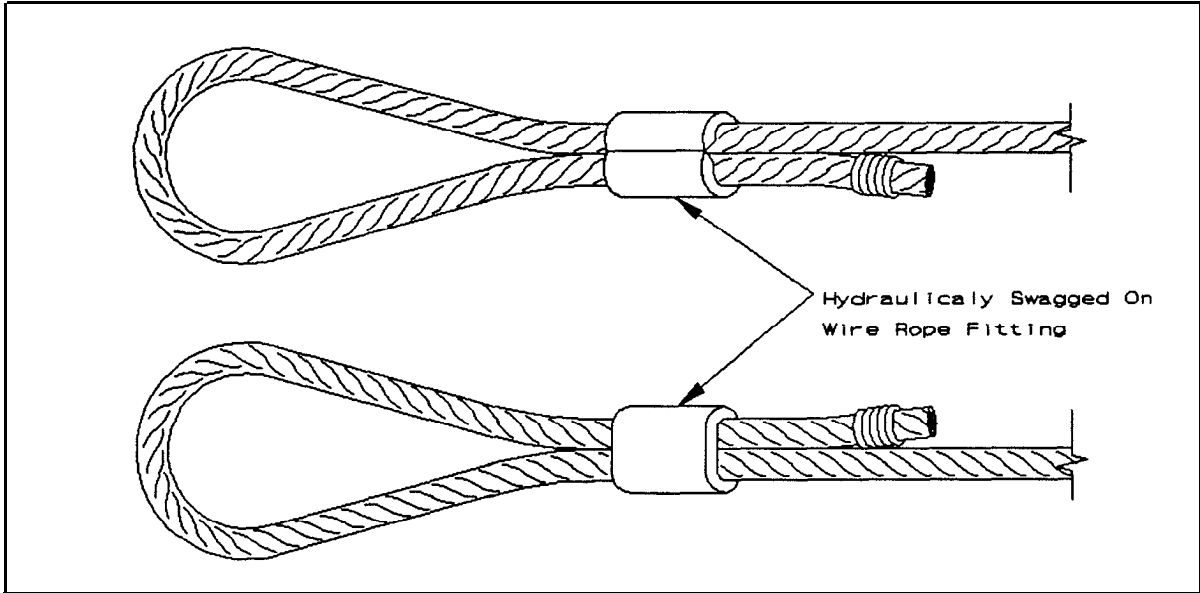

Figure 26.
Hydraulically Swaged Wire Rope Fitting.

The critical component of the gate reinforcement system is the chain used to fasten the gates together. When the gates are closed, a 1/2-inch (12.7-mm) diameter welded steel alloy chain conforming to RR-C-271 (Table 2, Type 1, Grade C, Class 1), is passed through each of the wire rope loops at the opening and around the two upright gate posts, then snugly fastened together with a Medium Security Padlock (MIL-P-43951) as shown in Figure 24.

There are times when a gate reinforcement cable barrier system is desired but a cable reinforcement system for the adjoining fence is not

necessary since terrain, natural barriers, structures, or other passive barrier features provide vehicle crash protection adjacent to the gate. In such cases, the gate cable system can be terminated directly on each side of the gate with the deadman concrete anchors described for the vehicle restraint cable system in Section 2.

3.7.2 Reinforcement of Sliding and Vertical Lift Gates. While there is no "generic" or standard solution for hardening the various configurations of sliding and vertical lift gates that may be designed, the reinforcement materials used for swing gates above may be used effectively by the designer to reinforce either sliding or vertical lift gates.

For example, a 3/4-inch (19.1-mm) wire rope (cable) (MIL-W-83420) could be attached along the length of a sliding gate as shown in Figure 27 or a vertical lift gate as shown in Figure 28. The cable ends are then looped securely around the gate frame uprights at each end as shown in Figure 29. The end of the fence reinforcement cable system should be looped around the terminal posts on each side of the gate opening as shown for gate posts for swing gates in Figure 22. A 1/2-inch (12.7-mm) diameter welded steel alloy chain conforming to RR-C-271 (Table 2, Type 1, Grade C, Class 1), can then be passed around the fence terminal post and the gate frame upright, passing through both the fence and gate cable loops as shown in Figures 29 and 30. Again, all cable ends are looped and terminated with either three wire rope clamps (MS16842) as shown in Figure 25 or hydraulically swaged wire rope fittings (MIL-P-80104) as shown in Figure 26. A medium security padlock (MIL-P-43951) is used to snugly fastened the chain together as shown in Figures 29 and 30.

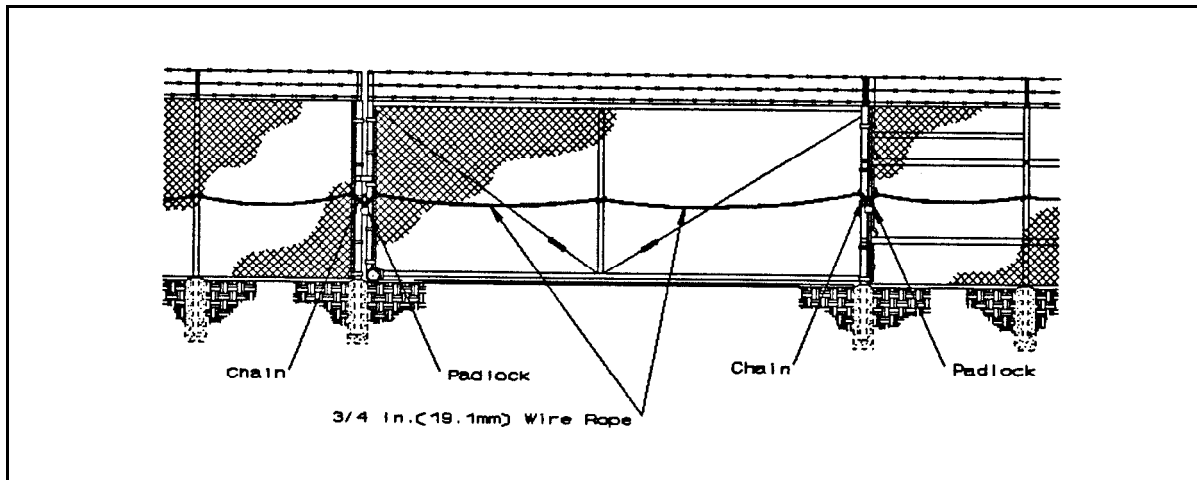

Figure 27.
Cable Reinforcement For a Sliding Gate.

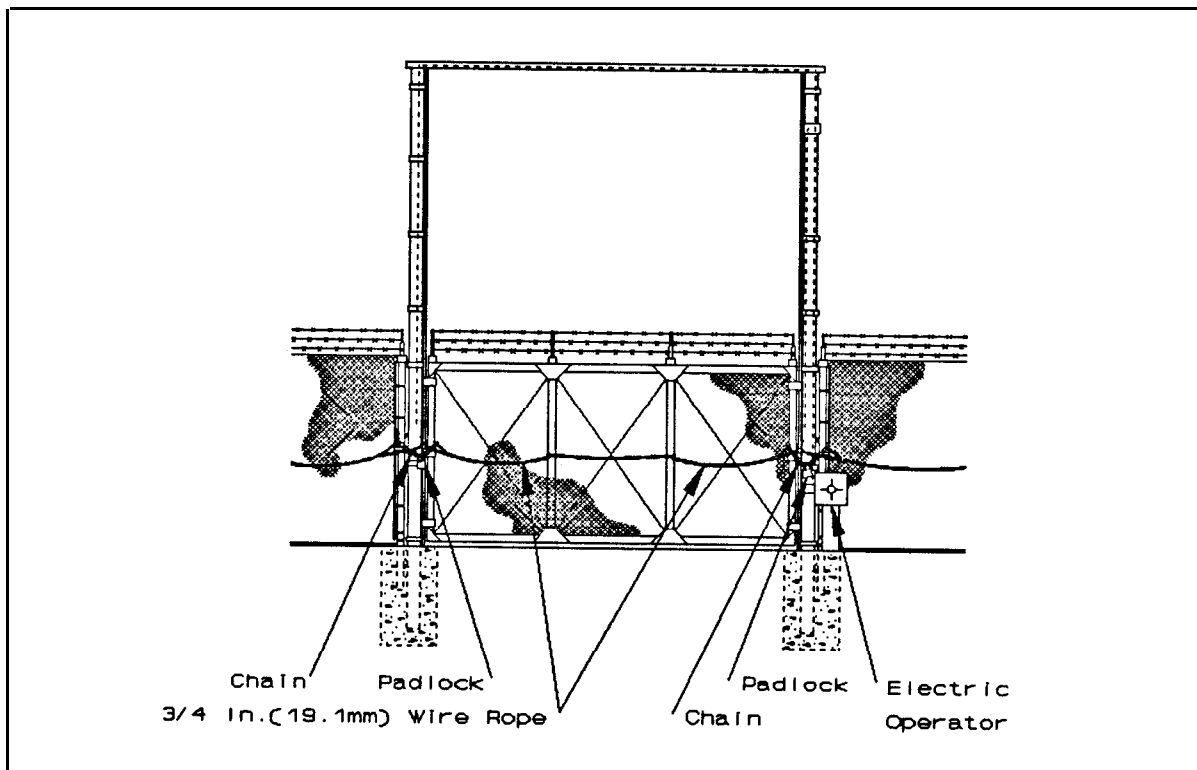

Figure 28.
Cable Reinforcement of a Vertical Lift Gate.

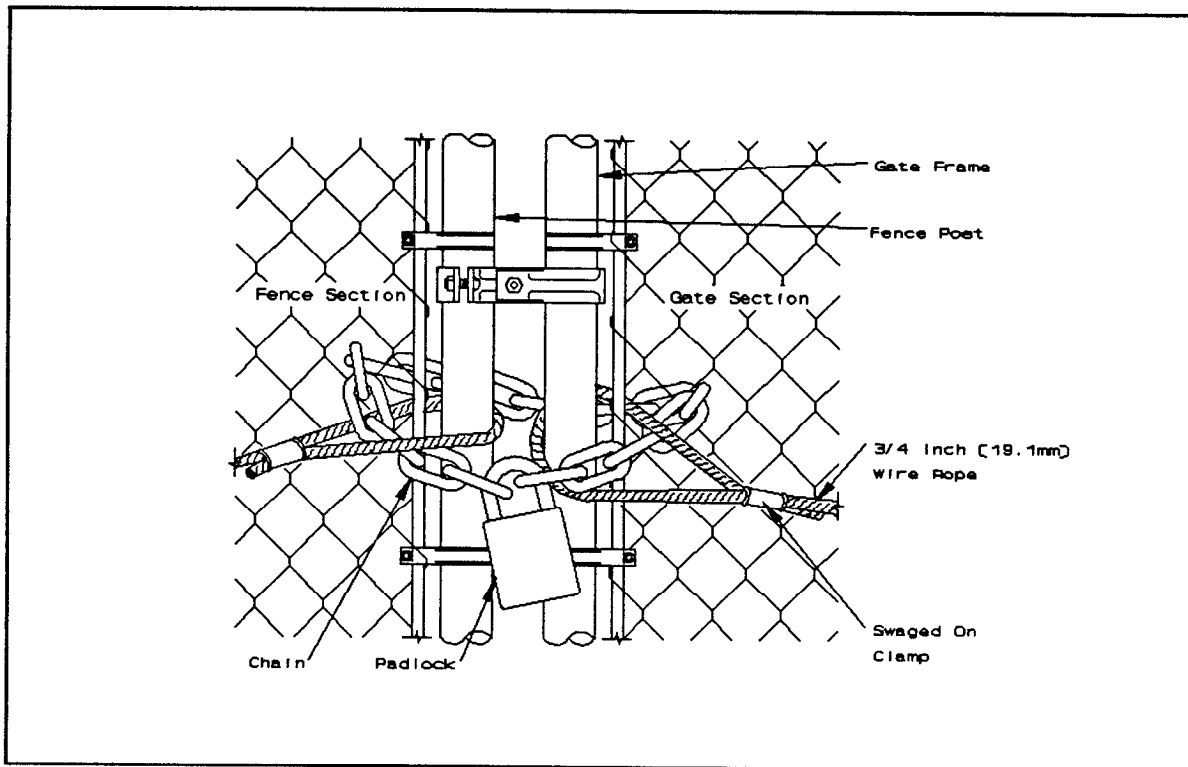

Figure 29.
Chain and Wire Rope Reinforcing Sliding Gate.

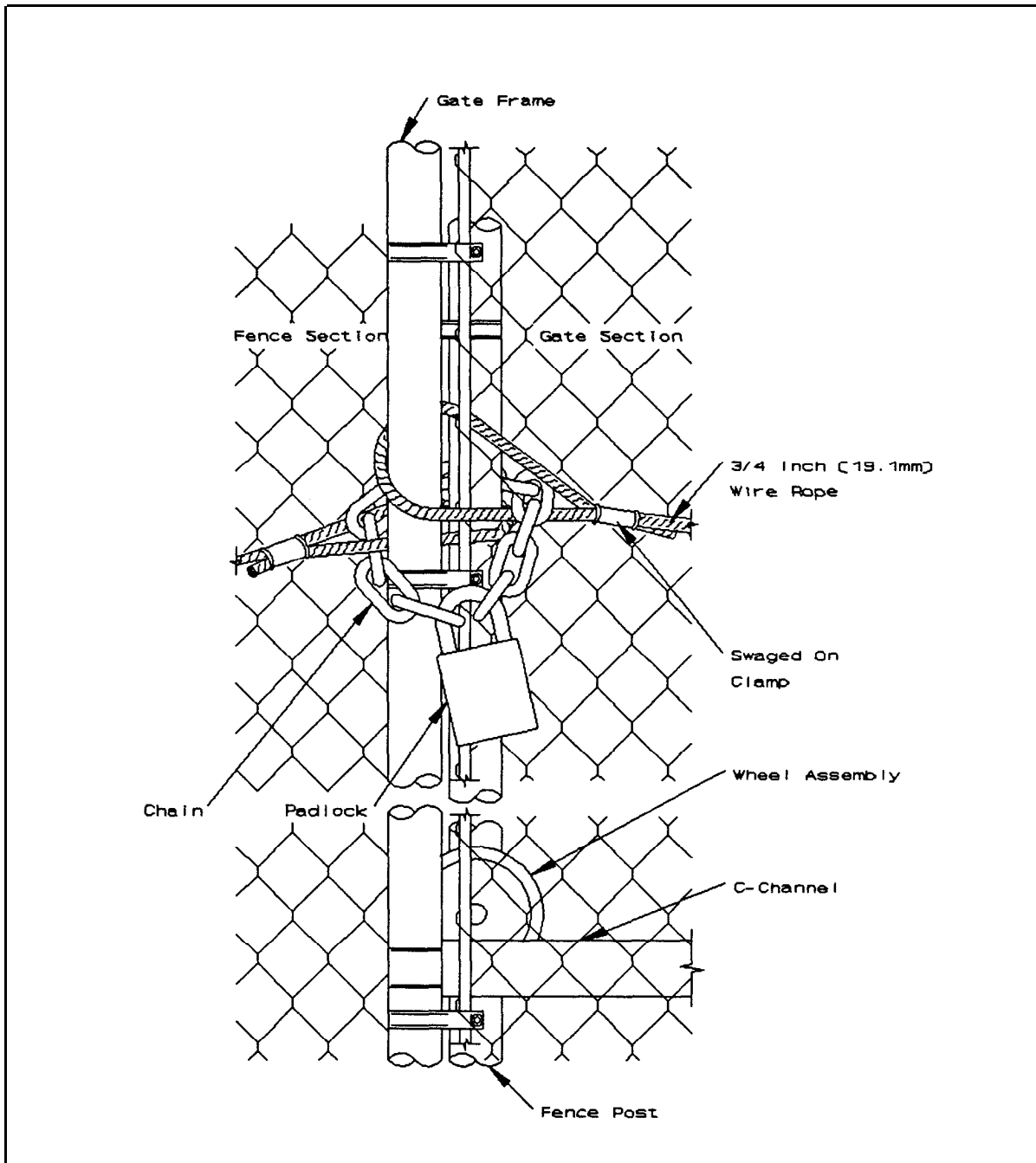

Figure 29 - Continued.
Chain and Wire Rope Reinforcing Sliding Gate.

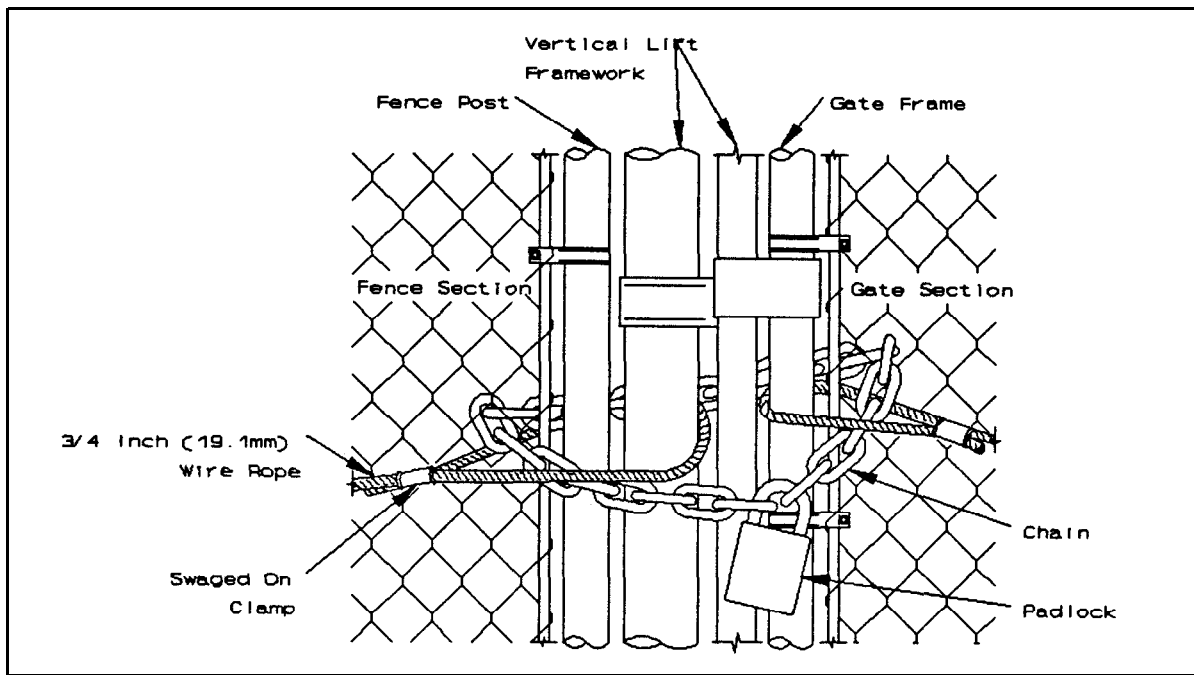

Figure 30.
Chain and Wire Rope Reinforcing Vertical Lift Gate.

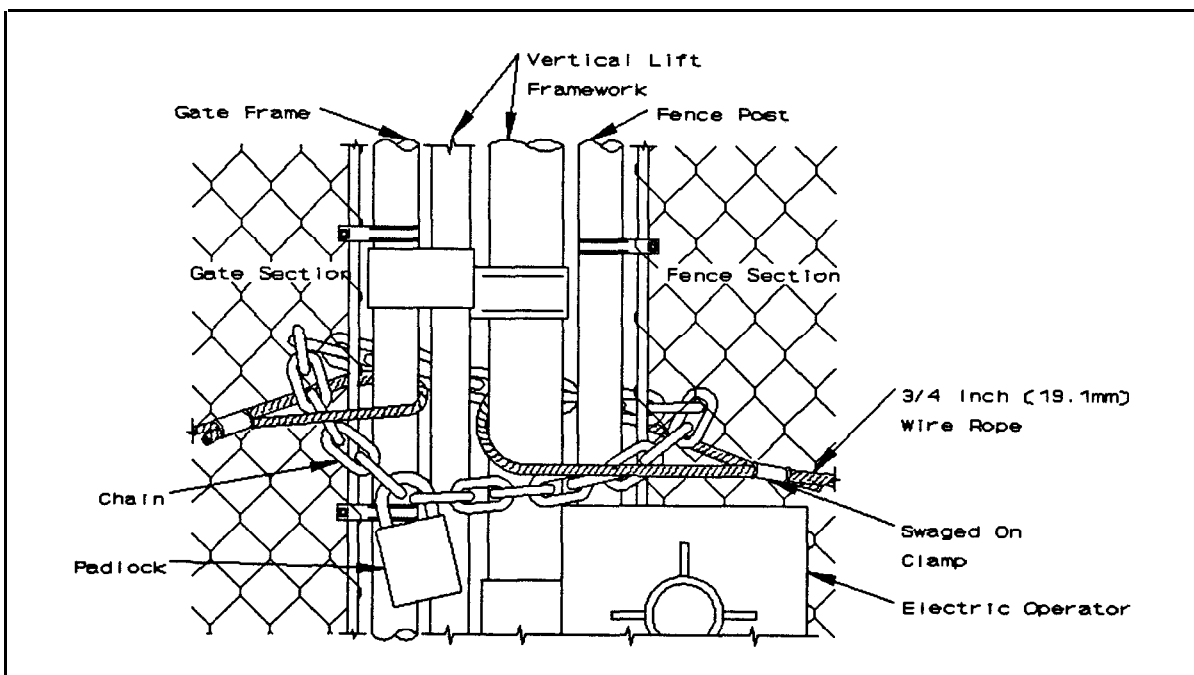

Figure 30 - Continued.
Chain and Wire Rope Reinforcing Vertical Lift Gate.

Section 4: GUARD FACILITIES

4.1 Application. Sentry booths, gatehouses, and guard towers are an integral part of a perimeter security system. Sentry booths and gatehouses are the points where personnel and vehicle control and badge exchange operations are conducted. Guard towers, properly designed and located around a restricted area, increase the range of observation and enhance the response of security personnel.

4.2 Related Criteria. MIL-HDBK-1013/1 designates four levels of security protection for structure design: low, medium, high, and very high. An associated design threat (attack tools or methods) along with the penetration delay time and ballistic resistance required for design is given for each level of protection. The determination of the category of security required against ballistic threats is a local command decision, with the exception of nuclear weapons storage sites. However, activity perimeter gate entry control booths or gatehouses should be provided with ballistic and medium threat level protection as a minimum.

4.3 Sentry Booths and Gatehouses. There are four levels of security to which a structure may be designed. Each level thwarts a specific design threat (low, medium, high, and very high). Similar to designing a security fence or gate for a restricted area, design of a sentry booth or gatehouse must begin with a physical site survey, evaluation of vehicular and pedestrian flow during operational and peak hours, and a thorough analysis of access control and security requirements contained in the Site Security Plan. In addition, a thorough local area threat analysis will aid in the decision of threat level design. For other than nuclear weapons storage sites, NAVFAC P-80, Facility Planning Criteria provides general criteria for use when designing sentry booths and gatehouses. Based upon these factors, basic design criteria can be determined such as:

- a) Maximum number of personnel required to be accommodated in the structure to effect security requirements.
- b) Ballistics and penetration resistance.
- c) Electronic and gate control equipment requirements, including location in the structure for optimum use by security personnel.
- d) Requirement for, and location of gun ports.
- e) Requirement for a rooftop fighting position with a parapet wall and access from the interior of the structure.
- f) Heating, ventilation, air conditioning (HVAC), and plumbing requirements.

For nuclear weapons storage facilities, all sentry booth or gatehouse designs shall be in accordance with NAVFAC P-272 Definitive Designs, NAVFAC Drawing 1404126, Physical Security Requirements for Special Weapons Storage Site. The NAVFAC Definitive Drawing is considered the minimum design and construction criteria for such facilities and are mandatory for facility certification.

4.3.1 Location. A sentry booth or gatehouse will be provided for all entrance gates that are manned by security personnel on a full or part-time basis. They should be located as close as possible to entry gates to permit personnel inside the booth or gatehouse to maintain constant surveillance over the entrance and approaches. In addition, site layout should allow for vehicle inspections or search without causing undue traffic backups. Figure 20 depicts an ideal entry control point, locations, and roadway clearances. Explosives safety criteria contained in NAVSEA OP 5, Volume 1, Ammunition and Explosives Ashore, Safety Regulations for Handling, Storing, Production, Renovation, and Shipping, must be considered in siting sentry booths and gatehouses at explosive component storage areas.

The entry control facility for nuclear weapons storage facilities is part of the perimeter security system and is the point from which personnel and vehicle control, and badge exchange operations are conducted. The personnel entry gate and access route shall be arranged and constructed to ensure that personnel pass the entry controller or badge exchange point and enter the area singly under the positive control of the security force (remotely operated gate, door, or turnstile controlled from within the gate house). See Figure 21 for a typical entry control facility for special weapons storage facility.

4.3.2 Site-Built Structures. As previously discussed, a thorough site analysis and review of operational requirements for the area involved must be accomplished prior to initiating design of sentry booths or gatehouses. NAVFAC P-80, Facility Planning Criteria, provides general spacing criteria and should be followed when designing sentry booths and gatehouses for other facilities. A typical site-built gatehouse is shown in Figure 31. Some basic considerations are provided in the following subparagraphs to assist the designer.

4.3.2.1 Structure Size. When determining structure size consider the number of personnel that will be assigned during normal operations, and the electronic and electrical equipment (e.g., communications equipment and gate controls) requirements. The mechanical support equipment (HVAC), storage space, and space provided for such equipment in addition to security personnel space allocations should also be determined. The surface area of any required counter or work space must be added to the overall floor space requirements for the structure.

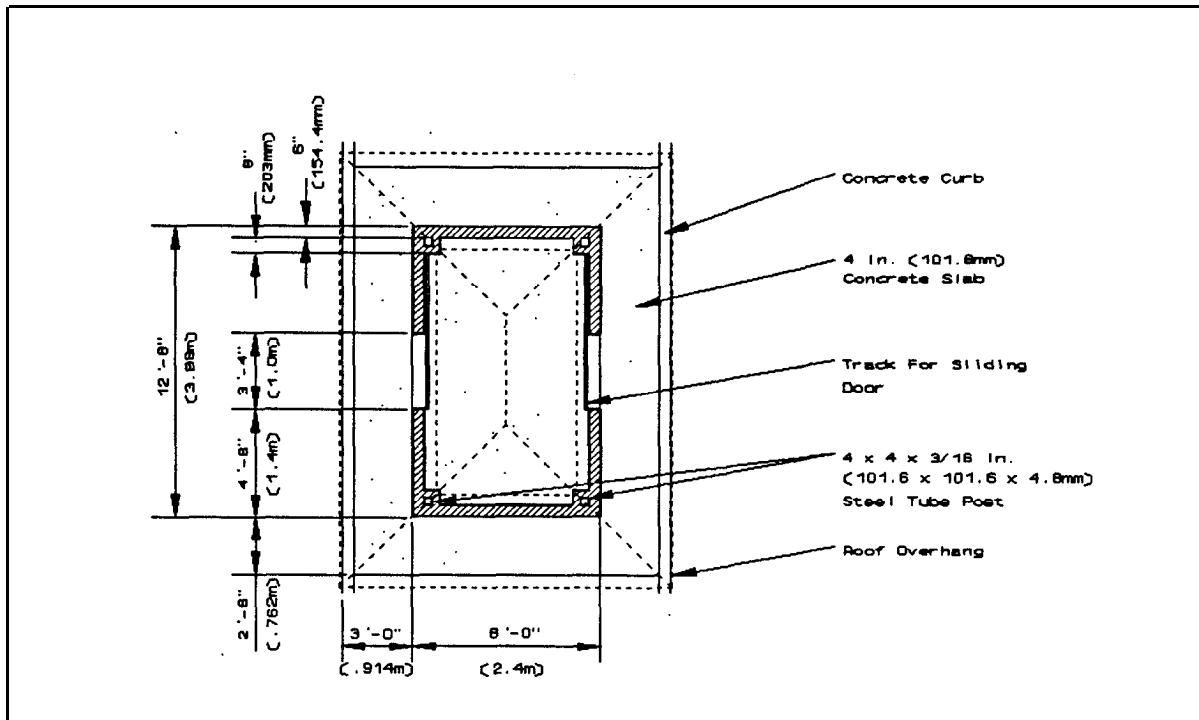

Figure 31.
Site-Built Sentry Booth/Gatehouse Floor Plan.

4.3.2.2 Windows. Windows selected for sentry booths and gatehouses should be placed at a continuous minimum height (normally 36 inches (914.4 mm) above the floor) at all elevations to maximize surveillance capability. Other options to consider are:

- a) Smoked or tinted glass.
- b) One way viewing.
- c) Ballistic-resistant glazing.

When designing or selecting ballistic-resistant glazing, be certain that the wall construction and adjacent products maintain the same level of protection. See MIL-HDBK-1013/1 for ballistic-resistance design information.

4.3.2.3 Floors. Floors will be constructed of reinforced concrete with the surface 6 inches (154.4 mm) or more above grade or adjacent walkways.

4.3.2.4 Construction. Based on the local area threat analysis and the level of protection required, the criteria contained in MIL-HDBK-1013/1 will

be of great value in designing walls, doors, and the roof of sentry booths and gatehouses.

4.3.2.5 Environmental Control. Conduct an analysis of the ambient temperatures to determine HVAC requirements. Consider heating due to electronic and electrical systems or fixtures, and security support equipment inside the structure. Determine HVAC requirements based on NAVFAC HVAC criteria for the local area. Insulate the walls and ceilings as required by NAVFAC criteria for the local area. As a minimum, provide cold water and soil lines if toilet facilities are required.

4.3.2.6 Lighting. Exterior lighting for sentry booths and gatehouses shall be 2.0-footcandle (20-lux) horizontal illumination during normal visibility conditions, and 6 inches (154.4 mm) above ground level. To minimize exposure of security personnel, use "glare protection" lighting at entry points. (The lighting will be directed at the gates with the gatehouse allowed to be in the shadows.) The interior lighting will be diffused lighting and designed with dimmer controls to aid with night vision and provide additional security to the occupants. Consider the use of a night light unit with a red lens. Connect lighting to a standby power source at the restricted area.

4.3.2.7 Grounding. Provide grounding protection. Refer to the National Fire Protection Association (NFPA) 78, Lightning Protection Code.

4.3.2.8 Fortification. Normally fortification requirements are driven by two factors: the local area threat level, and the requirements of the facility commander. Refer to MIL-HDBK 1013/1 for design criteria regarding attack hardening and ballistic resistance. When gun ports are required for sentry booths or gatehouses, consider the compatibility of gun ports to type of weapons, and attachments to be used (i.e., night vision scopes).

4.3.3 Prefabricated Structures. State-of-the-art prefabricated sentry booths and gatehouses offer an alternative to site-built structures. Prefabricated structures range from simple weather protection, to high-tech ballistics resistant. Resistance covers level I - level V and range from 1- to 60-minute forced entry resistance. Prefabricated structures can be ordered prewired to meet any electrical requirements desired. They can be procured with standard heating and air conditioning features. Additional options include gun ports, card pass trays, intercoms, and toilet facilities. A typical prefabricated structure is shown in Figure 32.

A thorough site analysis and review of operational requirements for the area involved must be accomplished prior to initiating design of sentry booths or gatehouses. Once the requirements are determined, the design engineer should request cost estimates from several manufacturers for the prefabricated structure. Each manufacturer offers a number of standard sizes or will custom build to specifications. A partial list of manufacturers can be found in Appendix A. Concurrently, an estimate for new construction of the

same structure should be prepared. After receiving the cost estimates for the prefabricated structures, a determination can be made as to which is the most cost-effective.

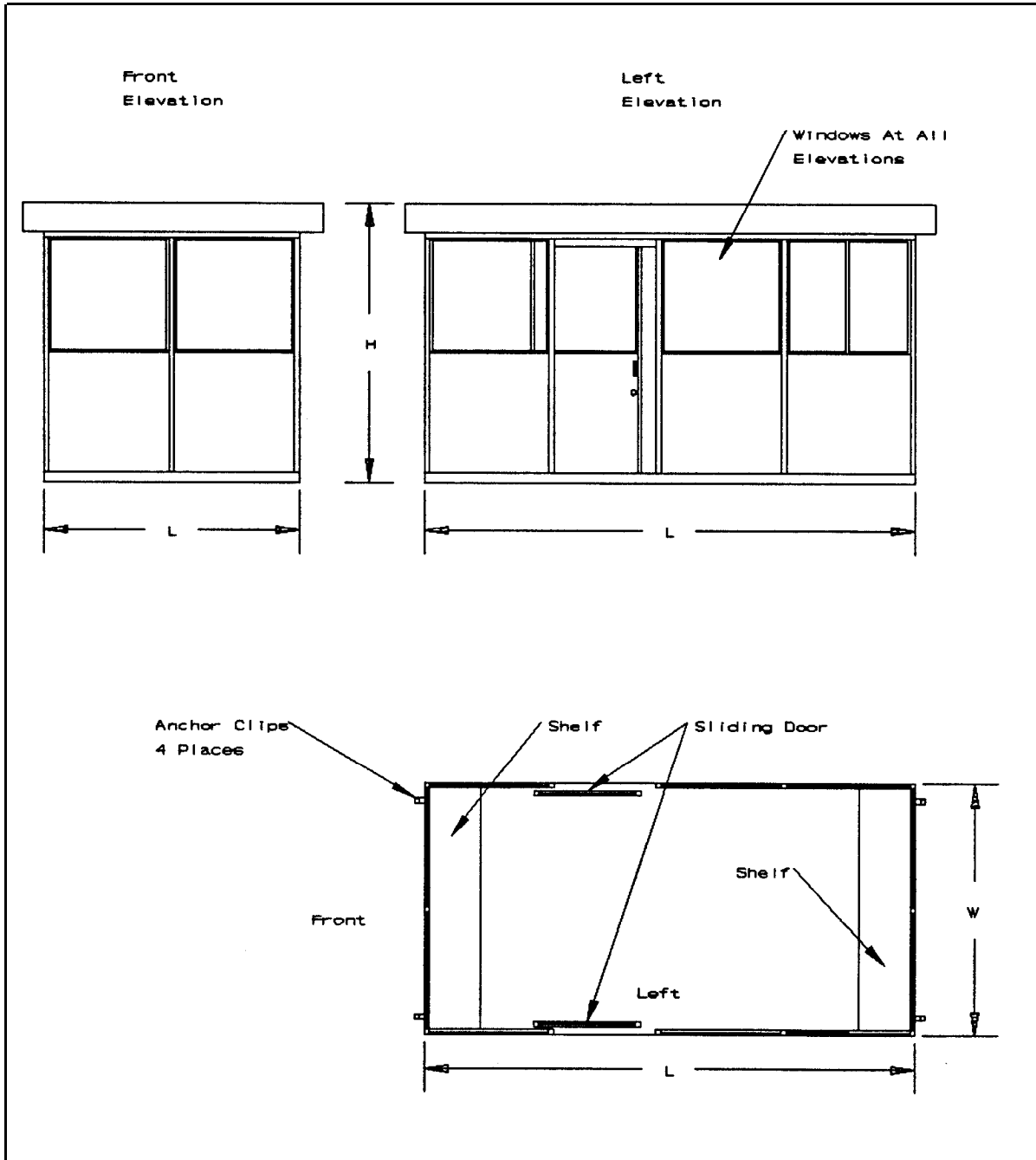

Figure 32.
Typical Prefabricated Sentry Booth.

4.4 Guard Towers. In the past, guard towers used for security purposes at military facilities have traditionally been constructed of a structural steel truss tower with an enclosed metal cab. This design has its limitations because personnel are exposed to potential attack while ascending to or descending from the cab. Design of guard towers must begin with a physical site study, terrain analysis, and an analysis of security requirements contained in the Site Security Plan. Based on this data, basic design criteria can be determined as follows:

- a) Maximum number of personnel required to be accommodated in the guard tower(s) to meet security requirements.
- b) Number of guard towers required.
- c) Installation requirements for electronic and communications equipment, including location in the guard tower for optimum use by security personnel.
- d) Requirement for, and location of gun ports.
- e) Heating, ventilation, air conditioning (HVAC), and plumbing requirements.

Guard tower design should provide small arms protection for security force personnel meeting ballistic threat levels III - IV. Guard tower design must include provisions to ensure that security personnel under duress are able to transmit signals discretely to other security personnel by either electrical, electronic, or oral means. Guard towers should be designed with a searchlight on the center of the roof, which can be rotated manually by the tower occupant.

4.4.1 Location and Height. The location and height of the guard tower that will best suit a particular facility depends to a great extent on the nature of the facility, the terrain to be under observation, the physical environment, and the functions that the tower will serve. Towers will be placed inside of the 30-foot (9.1-m) inner clear zone. The height to the cabin floor of the tower should normally be between 25 and 50 feet (7.6 and 15.2 m). For most facilities, the height to the cab floor is determined by the surrounding terrain, and the desires of the facility commander. The tower door should face another tower to allow the neighboring tower to visually monitor the tower door.

Guard tower cabins must be located so that the entire inner and outer clear zones and fence line can be observed. In hilly terrain and areas with heavy vegetation, a series of small guard towers may be required to maintain observation of the entire area. Explosives safety criteria contained in NAVSEA OP 5, Volume 1, Ammunition and Explosives Ashore, Safety Regulations for Handling, Storing, Production, Renovation, and Shipping, must be considered in siting guard towers at explosive component storage areas.

In order to be effective, the guard towers should be no more than 300 yards (274.3 m) apart.

4.4.2 Site-Built Structures. Conduct a thorough site analysis and review of operational requirements for the restricted area involved prior to initiating design of guard towers. While there is no specific size or floor spacing criteria for tower cabins, the designer should use analogous criteria contained in NAVFAC P-80.

4.4.2.1 Structure Size. The size of the tower cabin must be based on several factors. The first consideration is the number of personnel that will be assigned during normal or alert operations. Make a careful review of electronic and electrical equipment (e.g., communications equipment and, plumbing and mechanical support equipment (HVAC), and storage space (e.g., AA&E storage). Provide adequate space for the equipment, in addition to security personnel space allocations. Ensure that the surface area of any required counter or work space is added to the overall floor space requirements for the tower cabin.

4.4.2.2 Windows. Windows selected for tower cabins must meet the same ballistic threat level as the cabin construction itself. Ballistic-resistant glazing requirements are outlined in UL-752. Windows will not be less than 3 feet (0.91 m) high and will be located a minimum of 3 feet (0.91 m) above the cabin floor surface. They must be continuous around the entire cabin to maximize surveillance capability.

4.4.2.3 Construction. A new concept in guard tower design has been developed by Sandia National Laboratories in Albuquerque, New Mexico. This design consists of using precast concrete double tee beams placed vertically to form the walls of the tower, and a precast concrete cab placed atop the structure to house the guard quarters and surveillance equipment. Because a completely enclosed space is formed in the interior of the double tee shell, protection from attack and from extremes in weather conditions is provided. Due to the possibility of towers being constructed in diverse locations of the world, the design considered a 150-mph (241.4-km/hr) wind and zone 3 seismic loading. The tower is assumed to be supported on a spread footing with a maximum allowable bearing of 2,300 psf (11,230.9 kg/sq m). It should be noted that some areas may require specialized foundations such as piles, caissons, etc. Sandia indicated that all walls should be a minimum of 4 inches (101.6 mm) thick as this would provide excellent resistance to small arms projectiles, because double tee concrete will have a 28-day strength of 5,000-psi (3,515,500-kg/sq m) compressive strength. This also provides significant ballistic properties. A recommended, guard tower designed by Sandia National Laboratories is depicted in Figure 33. Design information can be obtained from NCEL.

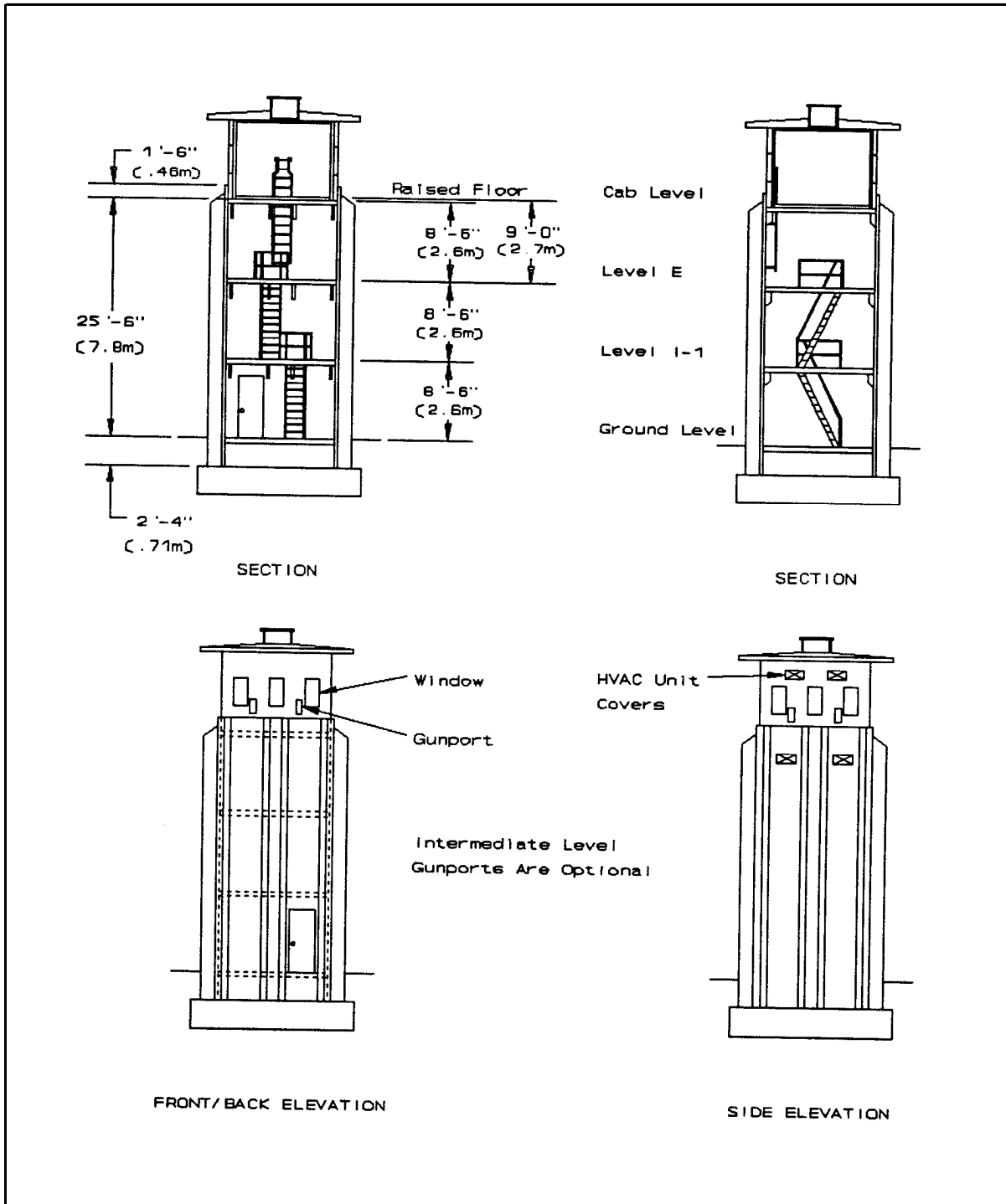

Figure 33.
Guard Tower Designed by Sandia National Laboratories.

4.4.2.4 Environmental Control. Conduct an analysis of the ambient temperatures to determine HVAC requirements. Consider heating due to electronic and electrical systems or fixtures, and security support equipment inside the structure. Determine HVAC requirements based on NAVFAC HVAC criteria for the local area. Insulate the walls, floor, and ceiling as required by NAVFAC criteria for the local area. As a minimum, provide cold water and soil lines if toilet facilities are required.

4.4.2.5 Lighting. Equip the tower cabin with interior lights furnished with dimmer controls to aid with night vision and additional security to the occupants. Provide a night light unit with a red lens and remote emergency lighting. Equip the roof of the cabin with a moveable searchlight, controllable from the interior of the cabin. The optimum recommended power for the searchlight is 500 watts, at 35,000-candle power. Connect all lighting to a standby power source, at the restricted area.

4.4.2.6 Grounding. Provide grounding and lightning protection. See National Fire Protection Association (NFPA) 78, Lightning Protection Code.

4.4.2.7 Fortifications. When gun ports are required for tower cabins, locations must be provided around the perimeter of the cabin. As a minimum, they should be designed to ensure that the security fence and the entire clear zone can be brought under fire. Other design considerations are the compatibility of gun ports to type of weapons and attachments to be used (i.e., night vision scopes).

4.4.2.8 Stairs and Ladders. Conduct an analysis of the anticipated threat in the local area to determine if a requirement exists for providing a ballistic-resistant enclosure for the stair or ladder used to access the tower cabin. The stairs up the tower should have periodic landings to ease the climb and facilitate maintenance of the inside of the tower. A rectangular stair configuration is recommended as opposed to a circular one. A ship's ladder and hatch will make the transition from the stairs through to the tower cab possible. When a ballistic-resistant enclosure is provided for the stair or ladder, an intrusion detection sensor and a remotely controlled access system shall be installed on the ground level at the hardened access door.

4.4.3 Prefabricated Structures. State-of-the-art prefabricated guard towers offer ballistic resistance that meets the requirements and standards for threat levels I - IV. A prefabricated tower system consists of a cabin with a roof, floor and sidewalls, access hatches, vision windows, and gun ports. Where required, a hardened tower "tunnel" with circular or standard riser stairway, hardened personnel access door, shrouded HVAC ports, and a security lighting package may be ordered from manufacturers. The cabin and tower are built with ballistic-resistant steel. All of the steel surfaces are painted with rust inhibiting primer, and finish paint.

Conduct a thorough site analysis and review of operational requirements for the area involved prior to initiating design of guard towers. Once the

requirements are determined, the design engineer should request a cost estimate from the manufacturer for a prefabricated structure meeting the requirements desired. Having received estimates for the prefabricated structure and the site-built structure, a cost analysis and a determination can be made as to which is the most economical. Each manufacturer offers a number of standard sizes or will custom build to specifications. A partial list of manufacturers can be found in Appendix A.

4.4.4 Ballistic-Resistant Materials Data. For information regarding state-of-the-art developments in arms, ammunition and ballistic-resistant materials, including glazing materials and lightweight armor which are not discussed in this handbook, refer to MIL-HDBK-1013/1 or:

Naval Civil Engineering Laboratory
Security Engineering Division (Code L56)
560 Laboratory Drive
Port Hueneme, CA 93043-4328
Commercial: (805) 982-9640
DSN: 551-9640

APPENDIX A
MANUFACTURERS

SECURITY BOOTH/GUARD TOWERS

Company Name/Address	Phone
B.I.G. Enterprises Inc. 9072 E. Rush Street South Wlmonete, CA 91733-1730	(818) 448-1449
Chicago Bullet Proof Equipment Co. 2250 Western Avenue Park Forest, IL 60466-1298	(708) 481-3400
National Bullet Proof Inc. 9855 S. 78th Avenue Hickory Hills, IL 60457	(708) 430-3200
Norment Industries PO Drawer 6129 Montgomery, AL 36106-0129	(205) 281-8440

FENCE FASTENERS

Security Fabricators, Inc. 321 Lafayette Avenue P. O. Box 643 Kenilworth, NJ 07033	(908) 272-9171
---	----------------

REFERENCES

NOTE: THE FOLLOWING REFERENCED DOCUMENTS FORM A PART OF THIS HANDBOOK TO THE EXTENT SPECIFIED HEREIN. USERS OF THIS HANDBOOK SHOULD REFER TO THE LATEST REVISIONS OF THE CITED DOCUMENTS UNLESS OTHERWISE DIRECTED.

FEDERAL/MILITARY SPECIFICATIONS, STANDARDS, BULLETINS, HANDBOOKS, AND NAVFAC GUIDE SPECIFICATIONS: Unless otherwise indicated, copies are available from Defense Printing Service, Standardization Document Order Desk, Building 4 D, 700 Robbins Avenue, Philadelphia, PA 19111-5094

Department of Defense Index of Specifications and Standards (DODISS).

SPECIFICATIONS

RR-C-271	Chains and Attachments, Welded, Weldless.
RR-F-191/GEN	Fencing, Wire and Post Metal (and Gates, Chain-Link Fence Fabric, and Accessories) (General Specification).
RR-F-191/1	Fencing, Wire and Post, Metal (Chain-Link Fence Fabric).
RR-F-191/2	Fencing, Wire and Post, Metal (Chain-Link Fence Gates).
RR-F-191/3	Fencing, Wire and Post, Metal (Chain-Link Fence Posts, Top Rails, and Braces).
RR-F-191/4	Fencing, Wire and Post, Metal (Chain-Link Fence Accessories).
MIL-B-45908	Bolt, Eye, General Specification.
MIL-B-52489	Barbed Tape Concertina.
MIL-P-80104	Press, Swaging, Wire Rope Fittings, (Hydraulic.
MIL-P-43951	Padlock, Medium Security.
MIL-W-83420	Wire Rope, Flexible, For Aircraft Control.
MS16842	Clamp, Wire Rope, Saddled, Single Grip, Steel.
MS51561	Turnbuckle, Round Body, Eye and Eye, (Type I).

HANDBOOKS

MIL-HDBK-1004/6	Lightning Protection.
MIL-HDBK-1005/3	Drainage Systems.
MIL-HDBK-1013/1	Design Guidelines for Physical Security of Fixed Land-Based Facilities.
MIL-HDBK-1013/4	Instruction for Design, Fabrication and Construction/Installation of Secure Enclosures.
MIL-HDBK-1013/5	Steel-Ply Wall Hardening Selection and Installation Guide.
MIL-HDBK-1013/7	Security Hardware Installation, Operation and Maintenance.
MIL-HDBK-1013/8	Combination Locks.

OTHER GOVERNMENT DOCUMENTS AND PUBLICATIONS: Unless otherwise indicated, copies are available from National Technical Information Service, 5285 Port Royal Road, Springfield, VA 22161, Attn: Defense Publications.

DM-5.14	Groundwater Pollution Control.
DM-13.02	Commercial Intrusion Detection Systems (IDS).
NAVFAC P-80	Facility Planning Criteria.
NAVFAC P-272	Definitive Designs.
NAVSEA OP 5, VOL 1	Ammunition and Explosives Ashore, Safety Regulations for Handling, Storing, Production, Renovation, and Shipping.
NCEL TVBSM	Terrorist Vehicle Bomb Survivability Manual, July 1988.
OPNAVINST 5530.13A	Physical Security Instruction for Conventional Arms, Ammunition, and Explosives.
OPNAVINST 5530.14B	Physical Security and Loss Prevention.
OPNAVINST C8126.1	Navy Nuclear Weapons Security Manual (U).
NAVFACINST 11012.134A	Security Measures in the Planning and Design of Nuclear Weapons Facilities

NON-GOVERNMENT PUBLICATIONS:

ASTM A 90	Standard Test Method for Weight of Coating on Zinc-Coated Galvanized Iron or Steel Articles.
ASTM A 116	Zinc-Coated (Galvanized) Steel Woven Wire Fence Fabric.
ASTM A 120	Pipe, Steel, Black and Hot-Dipped Zinc-Coated (Galvanized) Welded and Seamless, for Ordinary Uses.
ASTM A 121	Zinc-Coated (Galvanized) Steel Barbed Wire.
ASTM A 392	Zinc-Coated Steel Chain-Link Fence Fabric.
ASTM A 428	Standard Test Method for Weight of Coating on Aluminum-Coated Iron or Steel Articles.
ASTM A 491	Aluminum-Coated Steel Chain-Link Fence Fabric.
ASTM A 552	Definition of Terms Relating to Chain-Link Fencing.
ASTM A 584	Aluminum-Coated Steel Woven Wire Fence Fabric.
ASTM A 585	Aluminum-Coated Steel Barbed Wire.
ASTM A 817	Metallic-Coated Steel Wire for Chain-Link Fence Fabric.
ASTM F 567	Standard Practices for Installation of Chain-Link Fences.
ASTM F 626	Standard Specification for Fence Fittings,
ASTM F 668	Poly Vinyl Chloride (PVC)-Coated Steel Chain-Link Fence Fabric.
ASTM F 669	Strength requirements of Metal Posts and Rails for Industrial Chain-Link Fence.
ASTM A 824	Metallic-Coated Steel Marcellled Tension Wire for Use With Chain-Link Fence.
ASTM F 900-84	Specifications for Industrial and Commercial Swing Gates.

ASTM F 1083

Pipe, Steel, Hot-dipped Zinc-Coated (Galvanized)
Welded, for Fence Structures.

(Unless otherwise indicated, subscriptions are available from American Society for Testing and Materials (ASTM), Philadelphia, PA 19103.)

NFPA 78

Lightning Protection Code.

(Ordering information may be obtained upon request from the National Fire Protection Association (NFPA), 1 Batterymarch Park, P.O. Box 9101, Quincy, MA 02269-9101. This document may also be available in or through libraries or other informational services.)

UL 752

Bullet Resisting Equipment.

(Ordering information may be obtained upon request from Underwriters Laboratories Inc. (UL), Publications Stock, 333 Pfingsten Road, Northbrook, IL 60062.)

GLOSSARY

Fence items indicating a parenthetical number in this Glossary are shown in Figure 34.

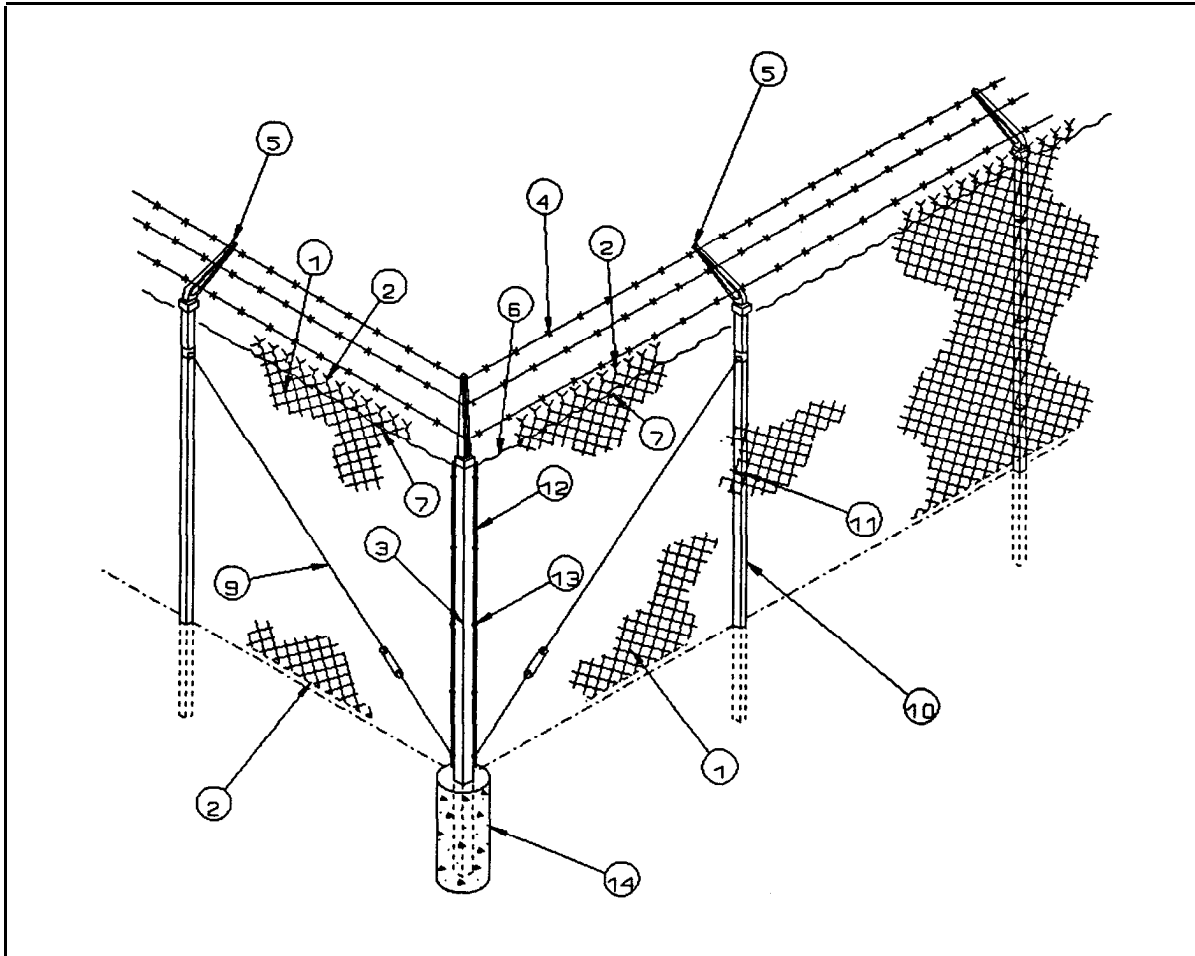

Figure 34.
Basic Components of a Chain-Link Fence.

AA&E. Arms, ammunition, and explosives.

Aluminized. (In chain-link fabric). Describes fabric that is woven from steel wire that is coated with aluminum before weaving.

ASTM. American Society for Testing Materials.

Barb Wire Arm (5). An arm connected to a line post which supports 3 strands of barbed wire on an inward or outward 45 degree angle or in a vertical position. V-type barbed wire arms are available to accommodate 6 strands of barbed wire.

Barbed Wire (4). Protective wire available with the 4-point barbs spaced either 3 inches or 5 inches (75 or 127 mm) apart.

Barbed Tape. A flat steel strip fabricated such that the material exhibits sharp barbs, or clusters of barbs, intended for use as an anti-personnel barrier.

Brace Band. A symmetrically formed strip of metal shaped to fit around a post used to attached the rail end to the post.

Brace Rail. A rail used in conjunction with the truss rod to form a structural support between terminal post and adjacent line post.

CCTV. Closed circuit television.

Center Stop. A device to receive and hold the drop bar on a double gate.

CMC. Commandant of the U.S. Marine Corps.

CNO. Chief of Naval Operations.

Concrete Footing (14). Terminal post footings should be 12 inches (300 mm) wide and 36 inches (1 m) deep. Line post footings should be 10 inches (250 mm) wide and 36 inches (1 m) deep. When solid rock is encountered, a hole is core drilled 1-inch (25 mm) larger than the diameter of the post, 12 inches (300 mm) deep, and the post grouted into place.

Corner Post (3). A terminal post, used where the direction of the fence line changes direction.

Diamond. The opening formed by the woven wires in chain link fence fabric.

Diamond Count. The number of diamond openings from one edge of fabric to the other. The count of a given fabric shall begin at the first completed diamond at one edge and continue to the unfinished (half) or full opening at the other edge.

DM. Design Manual.

DODISS. Department of Defense Index of Specifications and Standards.

ECP. Entry Control Point.

End Post. The terminal post at the end of a line of fence.

Fabric (1). A fencing material made from wire helically wound and interwoven in such a manner as to provide a continuous mesh without knots or ties except the knuckled or twisted ends of the wires to form selvages of the fabric. Fabric is available in various widths, gauges, breaking strengths, and protective coatings.

Flange. A plate or casting for securing a post to a floor or a horizontal rail to a wall.

Frame Hinge. A fitting that attaches to the gate frame and functions with the post hinge.

Framework. The basic structure supporting installed fabric, namely the post, rails, and tension wires.

Galvanized. Zinc-coating of steel materials.

Galvanized After. Describes steel chain-link fabric that is coated after weaving.

Galvanized Before. Describes steel chain-link fabric that is coated before weaving.

Gate Frame. The structural member(s) of the gate.

Gate Hold Back. A device to receive and hold the gate leaf in the open position.

Gate Latch. A fitting to hold the gate in place when closed.

Gate Post. The post to which a gate is attached via hinges. It may also be used as terminal post.

Height. The distance across the fabric from one selvage edge to the other.

Hog Ring (7). A C-shaped wire clip which attaches the tension wire to the chain-link fabric at approximately 24-inch (.60 m) intervals.

HVAC. Heating, Ventilation, and Air Conditioning.

IAW. In accordance with.

IDS. Intrusion Detection System.

IR. Infrared beam.

km. Kilometers.

Knuckle. The selvage obtained by interlocking adjacent pairs of wire ends and bending the wire back into a loop.

Line Posts (10). Intermediate posts spaced a maximum of 10 feet (3.04 m) apart and considered to be the backbone of the fence line.

Line Rail Clamp. A fitting to secure mid-rail(s) or bottom rail or both, to the line post.

m. Meter.

Mesh (1). The clear distance between parallel wires forming a diamond.

MIL-HDBK. Military Handbook.

mm. Millimeter.

NATO. North Atlantic Treaty Organization.

NAVELEX. Naval Electronics Command.

NAVFACENGCOCM. Naval Facilities Engineering Command.

NFPA. National Fire Protection Association.

NSN. National Stock Number.

OPNAVINST. Chief of Naval Operations Instruction.

Picket. A single helically formed steel wire like those used in the manufacture of chain link fence fabric. Used for field splicing rolls of fabric into continuous chain link mesh.

Post Cap. A fitting atop a post usually to exclude water from tubular posts.

Post Hinge. A fitting that attaches to the gate post, the pintle of which fits the frame hinge permitting the gate to swing.

Pull Post. A terminal post used in a line of fence to brace a long stretch of fence or effect a change in elevation along the fence line.

PVC. Poly Vinyl Chloride coating used on fencing and fence materials.

Rail End. A cup-shaped fitting used with a brace to connect the top rail or brace to a post.

Scroll. A decorative ornament on top of a gate.

Selvage (2). The manufactured finish to the top and bottom edges of the fabric.

Sleeve Top Rail. A fitting used to join two pieces of top rail when a swaged top rail is not used.

Stretching. The process of putting tension on the fabric to make it hang uniformly along the line of fence between terminal post.

Swedge. The expanded end of a top rail that allows it to fit into and join another piece of top rail.

Tension Band. An offset strip of metal shaped to fit around the terminal post and attach the tension bar to the post.

Tension Bar (12). The bar which is threaded through the last vertical link of fabric. It attaches the fabric to the terminal post.

Tension Clip (13). A clip which attaches the tension bars to a square terminal post inserted into the post eliminating the need for wrap-around bands.

Terminal Post (3). The basic load-bearing component for a line of fence, to or from which the fabric is stretched; it may be an end, gate, corner or pull post.

Tension Wire (6). When top rail is not used, tension wire is installed within the top 6 inches (150 mm) of the fence. This heavy wire gives rigidity to the top of the fence.

Tie wire (11). Wire used to attach the fabric to the top rail and line post.

Top Rail. (Used in gate fabrication only) 1-3/8 inches (35 mm) O.D. round tubing gives support to the top of the fabric and offers a symmetrical appearance to the fence.

Truss Rod (9). A rod used in brace assemblies to draw and hold the line post firmly to the brace rail. The truss rod uses an adjustable turnbuckle to maintain proper tension.

Twist. The type of selvage obtained by twisting adjacent pairs of wire ends together in a close helix of 1-1/2 machine turns, which is equivalent to three full twists.

UL. Underwriters Laboratories, Inc.

CUSTODIAN:
NAVY - YD

PREPARING ACTIVITY:
NAVY - YD
PROJECT NO. FACR-1085